

OSNOVNA TERMINOLOGIJA ZA POTREBE ARHEOLOGIJE BRODA

Arheologija broda znanstvena je disciplina koja putem materijalnih ostataka, te pisanih, ikonografskih i etnografskih izvora proučava sve tipove brodova prošlih vremena. Zdenko Brusić, pionir podvodne arheologije u Hrvatskoj, započeo je intenzivan rad u podmorju šezdesetih godina prošloga stoljeća, u više navrata istražujući ostatke starih brodova. Sukladno suvremenoj metodologiji, u novije vrijeme pokazalo se kako je standardiziranje terminologije koja se koristi prilikom istraživanja prošlosti drvene brodogradnje neophodno za sustavno iznošenje rezultata istraživačkog rada, te poticanje znanstvene rasprave. U vrijeme dok je na Fakultetu strojarstva i brodogradnje Sveučilišta u Zagrebu još postojao predmet *Drvena brodogradnja*, Teodor Bernardi napisao je udžbenik *Konstrukcija drvenih brodova*, koji je u ovome radu, u nešto izmijenjenom obliku, poslužio kao osnova za pripremanje osnovnog pojmovnika. Taj pokušaj rezultat je sve intenzivnijih istraživanja ostataka drvenih brodova u hrvatskom podmorju, koja nužno dovode do potrebe izvještavanja i objave rezultata na hrvatskom jeziku.

KLJUČNE RIJEČI: *brod, drvena brodogradnja, arheologija broda, terminologija, standardizacija*

1. UVOD

Prema definiciji koju su u iscrpnom priručniku *L'archéologie navale* ponudili uvaženi stručnjaci Patrice Pomey i Erich Rieth, arheologija broda¹ znanstvena je disciplina koja putem materijalnih ostataka, te pisanih, ikonografskih i etnografskih izvora s tehničkog, funkcionalnog i društvenog stajališta proučava sve tipove brodova prošlih vremena, bez ikakvih ograničenja po pitanju njihove funkcije i geografskog podrijetla.² Britanski arheolog Keith

1 Eng. *nautical archaeology*; fr. *archéologie navale*; tal. *archeologia navale*. O arheologiji broda u terminološkom smislu vidi I. RADIC ROSSI, 2012.

2 P. POMEY, E. RIETH, 2005, 10.

BASIC NAUTICAL ARCHAEOLOGY TERMINOLOGY

Nautical archaeology is a scientific discipline that studies all types of ships from the past, based on material remains, and written, iconographic and ethnographic sources. Zdenko Brusić, the pioneer of Croatian underwater archaeology, started his intensive underwater research in the 1960s, and on several occasions explored the remains of old ships. In order to keep pace with modern methodology, it has recently become clear that a standardization of the terminology used in researching historical wooden shipbuilding is necessary to be able to systematically publish the results of research activities, and to promote scholarly discussion. At the time when the subject *Wooden Shipbuilding* was still taught at the Faculty of Mechanical Engineering and Naval Architecture of the University of Zagreb, Teodor Bernardi wrote a textbook entitled *Konstrukcija drvenih brodova (Wooden Ship Construction)*. His textbook served as the starting point for compiling an initial Croatian nautical archaeology glossary. This paper builds on his glossary, and is the result of intensive recent excavations of wooden ship remains in Croatian waters, which have necessarily involved the need to report and publish results in Croatian.

KEYWORDS: *ship, wooden shipbuilding, nautical archaeology, terminology, standardisation*

1. INTRODUCTION

According to the definition offered in *L'archéologie navale*, a comprehensive handbook written by the respected experts Patrice Pomey and Erich Rieth, nautical archaeology¹ is a scientific discipline studying all types of ships from the past from the technical, functional and social point of view, based on material remains and written, iconographic and ethnographic sources, without any restrictions in terms of the ships' function and geographical origin.² The

1 En. *nautical archaeology*; Fr. *archéologie navale*; It. *archeologia navale*. On the term *nautical archaeology*, see I. RADIC ROSSI, 2012.

2 P. POMEY, E. RIETH, 2005, 10.

Muckelroy definirao je brod kao oruđe namijenjeno transportu, svrsishodan funkcionalan element unutar određenoga ekonomskog ili vojnog sustava i zatvorenu zajednicu s jasno određenom hijerarhijom, običajima i pravilima ponašanja,³ a slavni njemački filozof Johan Wilhelm Friedrich Hegel opisao ga je sljedećim riječima: „Brod, labud mora, koji hitrim i skladnim kretnjama presijeca valovitu površinu ili povlači na njoj kružnice, jest oruđe kojega izum čini najveću čast kako ljudskoj odvažnosti, tako i njegovu razumu.“⁴

Polovicom 19. stoljeća termin *archéologie navale* prvi je u stručnu literaturu uveo Augustin Jal.⁵ U suvremenom smislu, metodologija arheologije broda u Mediteranu razvila se, međutim, tek više od jednog stoljeća kasnije, kao posljedica naglog razvoja podvodnih arheoloških istraživanja. Iako su podvodna otkrića pozitivno djelovala na razvoj arheologije broda, ona su uzrokovala i stvaranje iskrivljene slike o njezinu stvarnom sadržaju. Ne ulazeći u obimnije rasprave o pogrešnim predodžbama koje nastaju kad se arheologija broda nastoji poistovjetiti s podvodnom arheologijom, na koje upozoravaju i autori Pomey i Rieth,⁶ spominjem samo činjenicu kako je u slučaju arheologije broda riječ o terminu kojim se označuje znanstvena disciplina s jasno definiranom metodologijom rada, koja predmete istraživanja pronalazi kako na kopnu tako i pod vodom te se time bitno razlikuje od tehničkog izraza kojim se uobičajeno označuju sva arheološka istraživanja provedena u posebnim uvjetima pod vodenom površinom.

2. ZDENKO BRUSIĆ I ZAČETCI RAZVOJA ARHEOLOGIJE BRODA U HRVATSKOJ

Zdenko Brusić, često zvan pionir podvodne arheologije u Hrvatskoj, započeo je svoj intenzivan rad u podmorju šezdesetih godina prošloga stoljeća, te ga nastavio tijekom čitavog životnog vijeka. U svojoj istraživačkoj karijeri bavio se podmorskim nalazištima iz svih vremenskih razdoblja, u više navrata istražujući upravo ostatke starih brodova. Prvi u nizu njegovih projekata koji pripadaju domeni arheologije broda bio je istraživanje dvaju sred-

British archaeologist Keith Muckelroy defined a ship as a machine designed for transport; a relevant functional element in a military or economic system, and a closed community with its own hierarchy, customs, and conventions.³ The famous German philosopher Georg Wilhelm Friedrich Hegel described it in the following terms: “The Ship — that swan of the sea, which cuts the watery plain in agile and arching movements or describes circles upon it — is a machine whose invention does the greatest honor to the boldness of man as well as to his understanding.”⁴

In the mid-19th century, the term *archéologie navale* was first introduced into the professional literature by Augustin Jal.⁵ However, the modern methodology of nautical archaeology in the Mediterranean did not develop until more than a century later as a consequence of the sudden development of underwater archaeological exploration. Although underwater discoveries had a positive impact on the development of nautical archaeology, at the same time they also caused a distorted image concerning its actual nature. Without entering into a comprehensive discussion on the misperceptions, which are the consequence of the attempt to identify nautical archaeology with underwater archaeology, as anticipated by Pomey and Rieth,⁶ I would like to point merely to the fact that the term *nautical archaeology* denotes a scientific discipline with a clearly defined methodology. Its objects of research are found both on land and under water, making it essentially different than a technical expression to denote archaeological campaigns conducted under special conditions under the water's surface.

2. ZDENKO BRUSIĆ AND THE BEGINNINGS OF THE DEVELOPMENT OF NAUTICAL ARCHAEOLOGY IN CROATIA

Zdenko Brusić, often called the pioneer of Croatian underwater archaeology, started his intensive underwater research in the 1960s, and continued throughout his lifetime. During his excavation career, he explored underwater sites from all time periods, and on several occasions excavated the remains of old ships. The first in a series of his projects in the field of nautical archaeology was the excavation of two medieval

3 K. MUCKELROY, 1978, 216.

4 J. W. F. HEGEL, 1966.

5 A. JAL, 1840.

6 P. POMEY, E. RIETH, 2005, 10.

3 K. MUCKELROY, 1978, 216.

4 G. W. F. HEGEL, 1966 (*Lectures on the Philosophy of World History*, translation by H. B. Nisbet, 1975).

5 A. JAL, 1840.

6 P. POMEY, E. RIETH, 2005, 10.



SL. 1. / FIG. 1.

Zdenko Brusić i supruga Desanka s modelom rekonstruirane srednjovjekovne brodice iz Nina (foto: I. Radić Rossi).

Zdenko Brusić and his wife Desanka, holding the model of the fully reconstructed mediaeval boat from Nin (photo: I. Radić Rossi).

njovjekovnih brodova u Ninu.⁷ Danas poznati pod imenom *Condura Croatica*, brodovi su 1974. godine izvađeni iz mora, a potom konzervirani i izloženi u Muzeju ninskih starina.⁸ Ono što taj projekt čini osebujnim za hrvatske prilike svakako je pokušaj rekonstrukcije ninskih arheoloških nalaza u vidu dvaju funkcionalnih plovila, izgrađenih u privatnom brodogradilištu u Betini (Sl. 1).⁹

Sljedeći značajan nalaz pojavio se krajem sedamdesetih godina u obližnjem Zatonu. U toj prostranoj luci antičke Enone (lat. *Aenona*) Brusić je uočio ostatke, jednog, a nedugo potom i drugog broda izrađenog tehnikom međusobnog spajanja platica šivanjem tj. vezanjem.¹⁰ Riječ je o staroj

ships in Nin.⁷ Now known as *Condurae Croaticae*, the ships were recovered from the sea in 1974, and subsequently conserved and exhibited at the Museum of Nin Antiquities.⁸ What makes this project distinctive in Croatian terms is the construction of two fully functional ships inspired by the Nin finds, built at a private shipyard in Betina⁹ (Fig. 1).

The next significant find appeared near the end of the 1970s in nearby Zaton. In the large port of the ancient *Aenona*, Brusić identified the remains of a ship, shortly followed by those of another, which was manufactured using the technique of fastening planks together by sewing, i.e. lashing, them together.¹⁰ This old Mediterranean technique, confirmed on

7 Z. BRUSIĆ, 1969; Z. BRUSIĆ, 1978.

8 R. JURIĆ, S. OGUIĆ, B. VILHAR, 1998.

9 Jedan je brod danas usidren u Ninu, dok se drugi nalazi u Zadru i povremeno se koristi za edukacijske i promidžbene aktivnosti.

10 Z. BRUSIĆ, 1968; Z. BRUSIĆ, M. DOMIJAN, 1985.

7 Z. BRUSIĆ, 1969; 1978.

8 R. JURIĆ, S. OGUIĆ, B. VILHAR, 1998.

9 One of the ships is currently anchored in Nin, while the other is kept in Zadar and occasionally used for educational and promotional activities.

10 Z. BRUSIĆ 1968; Z. BRUSIĆ, M. DOMIJAN, 1985.

mediteranskoj tehnici, višestruko potvrđenoj u pisanim izvorima i arheološkim nalazima arhajskog i klasičnog doba, koja se u Jadranu znatno duže održala.¹¹ I zatonski su brodovi izvađeni iz mora, ali se nažalost njihova dosadašnja sudbina znatno razlikuje od sudbine ninskih nalaza.¹²

Antički brodovi prapovijesne tradicije iz Zaton a i srednjovjekovni brodovi iz Nina napušteni su ili namjerno potopljeni u plitkome moru uz samu obalu. Takav položaj znatno je olakšao istraživanje i vađenje nalaza koji su svojom posebnosti privukli Brusićevu pozornost. Kao i u slučaju mnogih pionirskih istraživanja u Mediteranu, ograničene mogućnosti financijske i organizacijske prirode nadoknađene su velikim entuzijazmom malene istraživačke ekipe, a o osjetljivoj drvenoj građi posebnu je brigu, uglavnom zahvaljujući vlastitoj inicijativi i Brusićevoj podršci, poveo tadašnji konzervator-restaurator Arheološkog muzeja u Zadru Božidar Vilhar (Sl. 2).¹³ Sukladno ograničenim sredstvima i metodološkim znanjima koja su stručnjacima stajala na raspolaganju, istraživanja su provedena na iznimno visokoj razini, pa je doista šteta što se na njihovim temeljima arheologija broda u Hrvatskoj nije nastavila kontinuirano razvijati. Ne baveći se detaljno objavom ninskih nalaza, autori nisu imali potrebe za razradom pojmovnika, pa se na tome polju stvari nisu pomaknule s mjesta.

Kad su u pitanju brodovi koji leže na većim dubinama, dugogodišnja metodologija zaštite podmorskih arheoloških nalazišta duž hrvatske obale, zasnovana gotovo isključivo na vađenju ostataka lakše dostupnoga brodskog tereta i opreme, te napuštanju neistraženih i neprimjereno zaštićenih drvenih dijelova brodova na morskome dnu, dugi je niz godina sprječavala svako istraživanje koje bi se u punom smislu riječi moglo svrstati u domenu arheologije broda. U prilog takvoj tvrdnji govori činjenica da do početka 21. stoljeća u hrvatskom podmorju nije provedeno ni jedno sustavno istraživanje drvenih ostataka brodova koji leže na dubinama većim od nekoliko metara.¹⁴ Time je ujedno zaustavljen i razvoj primjerene terminologije, a izbor termina koji se primjenjivao pri opisivanju uzgred

many occasions in written sources and by archaeological finds from the Archaic and Classical period, continued to be exploited much longer in the Adriatic area.¹¹ The Zaton ships were also recovered, but unfortunately, their destiny has been significantly different from that of the Nin finds.¹²

The ancient ships at Zaton belonging to the prehistoric tradition and the medieval ships at Nin were abandoned or scuttled in shallow sea close to the coast. Due to their position, the excavation and recovery of these finds, whose distinctiveness had drawn Brusić's attention, were significantly easier. As in the case of many pioneering campaigns in the Mediterranean, the restricted financial and organisational resources were compensated for by the great enthusiasm of the small excavation team. Božidar Vilhar, then conservator at the Archaeological Museum of Zadar, took the special care of the delicate wooden remains, mostly thanks to his own initiative and Brusić's support (Fig. 2).¹³ Despite the restricted funding and the rudimentary level of methodological knowledge of that era, the excavations were conducted to an extraordinarily high standard. Therefore, it is a real pity that nautical archaeology in Croatia did not continue developing on these foundations. As the Nin finds were never published in detail, the authors probably did not deem it necessary to draw up a glossary of terms. Therefore, an initial opportunity for standardisation was lost.

When it comes to ships lying in deeper water, the long-time methodology for protecting submarine archaeological sites off the Croatian coast was based almost exclusively on recovering the remains of more easily accessible ship's cargo and equipment, and leaving wooden ship parts uninvestigated and inadequately protected on the seabed. For many years, this methodology resulted in excavations which cannot be classified as nautical archaeology in the full sense of the word. This can be seen from the fact that no systematic excavations of wooden ship remains lying at a depth greater than several metres were conducted in Croatian waters until the beginning of the 21st century.¹⁴ Such approach also hindered the development of appropriate terminology, and the selec-

11 Vidi rad G. BOETTO, C. ROUSSE, 2012 u kojem je sadržana ostala relevantna literatura.

12 I. RADIĆ ROSSI, Z. BRUSIĆ, 2014, 27.

13 Evidencija koja potvrđuje opisanu situaciju prikupljena je i analizirana u doktorskom radu autorice teksta: I. Radić Rossi, *Problematika prapovijesnih i antičkih nalazišta u hrvatskom podmorju*, 2011., Sveučilište u Zadru.

14 I. RADIĆ ROSSI, 2012, 223.

11 See the article G. BOETTO, C. ROUSSE, 2012 which quotes other relevant bibliography.

12 I. RADIĆ ROSSI, Z. BRUSIĆ, 2014, 27.

13 The records confirming this were collected and analysed in the doctoral thesis of the author of this text: I. Radić Rossi, *Problems of Prehistoric and Classical Antiquity Sites of the Croatian Undersea*, 2011, University of Zadar.

14 I. RADIĆ ROSSI, 2012, 223.

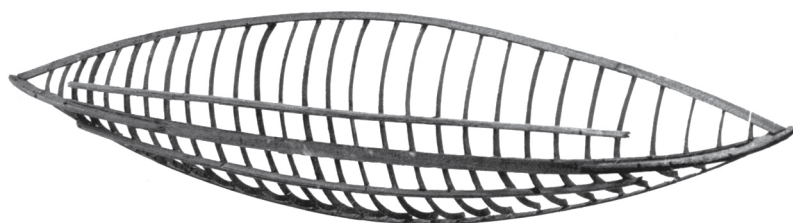

Sl. 2. / FIG. 2.

Božidar Vilhar tijekom rada na rekonstrukciji srednjovjekovnih brodica iz Nina i studijski model brodice Nin 1 (foto: Z. Brusić; model: B. Vilhar).

Božidar Vilhar working on the reconstruction of the mediaeval boats from Nin, and the study model of the boat Nin 1 (photo: Z. Brusić; model: B. Vilhar).

otkrivene drvene građe bio je krajnje ograničen i ponekad netočan.¹⁵

Nužnost sustavnog istraživanja broda kao jedinstvene cjeline u više je navrata naglasio George Bass,¹⁶ stručnjak čijom se zaslugom podvodna arheologija oblikovala prema svim metodološkim načelima svoje matične znanosti.

Usprkos neposjedovanju metodoloških znanja iz područja arheologije broda, Ksenija Radulić, voditeljica zaštitnog istraživanja kasnorenesansnog brodoloma kod otočića Gnalića u razdoblju od 1967.

tion of terms used in describing wooden inventory uncovered by chance was extremely restricted and sometimes inaccurate.¹⁵

The need to systematically explore a ship as a unique entity was highlighted on several occasions by George Bass,¹⁶ the expert who has shaped underwater archaeology in accordance with all the methodological principles of its parent science.

Despite a lack of methodological knowledge in the area of nautical archaeology, Ksenija Radulić, the leader of rescue excavation campaigns executed from

15 Najjasniji je primjer učestalo korištenje termina *kontrakobilica* za označavanje elementa koji s unutrašnje strane rebara prati kobilicu, a koji se u drvenoj brodogradnji naziva *hrptenica* ili *središnje pasmo*. Termin *kontrakobilica* ili *protukobilica* označava gredu koja se s donje strane dodaje na kobilicu s ciljem povećanja njezine čvrstoće (T. BERNARDI, 1964, 3, sl. 2). U pitanju je pogreška koja može navesti na potpuno krive zaključke, naročito u slučaju kad tekst ne prate fotografije ili crteži.

16 G. BASS, 2011, 10.

15 The clearest example is the frequent use of the term *kontrakobilica* (*rider keel* to denote the element which follows the keel on the inside of the frame, and which in wooden shipbuilding is called *hrptenica* or *središnje pasmo* (*keelson*). The term *kontrakobilica* or *protukobilica* (*rider keel*) denotes a beam which is added under the keel to increase its strength (T. BERNARDI, 1964, 3, Fig. 2). This mistake can lead to completely wrong conclusions, particularly when the text is not accompanied by photographs or drawings.

16 G. BASS, 2011, 10.



Sl. 3. / FIG. 3.

Sudionici zaštitnog istraživanja brodoloma kod otočica Gnalića 1967.; Zdenko Brusić prvi zdesna (arhiva Zavičajnog muzeja Biograd na Moru).

Participants of the rescue research campaign on the site of the shipwreck of Gnalić, in 1967; Zdenko Brusić first from the right (archive of the Local heritage museum of Biograd na Moru).

do 1973. godine, višestruko je, gotovo vizionarski, upozoravala na nužnost sustavnog istraživanja nalažišta, ne propustivši ni u jednoj prilici naglasiti važnost proučavanja drvenih ostataka broda.¹⁷ Zdenko Brusić je kao mladi arheolog i sam sudjelovao u podvodnim istraživanjima gnalićkog brodoloma 1967. i 1968. godine (Sl. 3), a nakon neuspjelog pokušaja obnove istraživanja 1996. godine svoju je punu podršku pružio svim kasnijim nastojanjima u tome smislu, te ponovnom pokretanju projekta 2012. godine.¹⁸

1967 to 1973 on a late Renaissance shipwreck near the islet of Gnalić, pointed to the need for a systematic excavation of the site on various occasions, using every opportunity to underline the importance of exploring the ship's wooden remains.¹⁷ Zdenko Brusić, as a young archaeologist, also participated in the underwater excavations of the Gnalić shipwreck in 1967 and 1968 (Fig. 3). After an unsuccessful attempt to relaunch the campaign in 1996, he fully supported all subsequent efforts in that direction before the project was eventually restarted in 2012.¹⁸

17 K. RADULIĆ, 1973; I. RADIĆ ROSSI *et al.*, 2013, 70, 73.

18 I. RADIĆ ROSSI *et al.*, 2013.

17 K. RADULIĆ, 1973; I. RADIĆ ROSSI *et al.*, 2013, 70, 73.

18 I. RADIĆ ROSSI *et al.*, 2013.

3. HRVATSKA POMORSKA TERMINOLOGIJA ZA POTREBE ARHEOLOGIJE BRODA

Godine 2007. u okviru međunarodne suradnje s francuskim Institutom za znanstvena istraživanja (CNRS – *Centre Camille Jullian*) započelo je planiranje zajedničkih istraživanja s namjerom da se u Hrvatskoj obnovi zanimanje za proučavanje stare brodogradnje i potakne razvoj potpuno zapostavljene znanstvene discipline arheologije broda.¹⁹ Uz suglasnost Zdenka Brusića, koji je i sam nastupio u ulozi suvoditelja međunarodnog projekta, kao probno nalazište za uvježbavanje sustavne primjene suvremene metodologije istraživanja brodske konstrukcije odabran je kasnoantički brodolom u podmorju otočića Velog Školja pred Pakoštanima (Sl. 4). Godine 2004. na tom je lokalitetu, pod Brusićevim vodstvom, obavljeno prvo probno istraživanje.

3. CROATIAN MARITIME TERMINOLOGY FOR THE NEEDS OF NAUTICAL ARCHAEOLOGY

In 2007, as part of international co-operation with the French National Centre for Scientific Research (CNRS – *Centre Camille Jullian*), the planning of a joint campaign commenced with the purpose of restoring interest in the study of ancient shipbuilding in Croatia and encouraging the development of the completely marginalised scientific discipline of nautical archaeology.¹⁹ As a test site for practising the systematic application of up-to-date ship-construction research methodology, in agreement with Zdenko Brusić, who acted as co-leader of the international project, a Late Antiquity shipwreck in the waters off the islet of Veli Školj near Pakoštane was selected (Fig. 4). In 2004, under Brusić's leadership, the first trial excavations were conducted at the site.

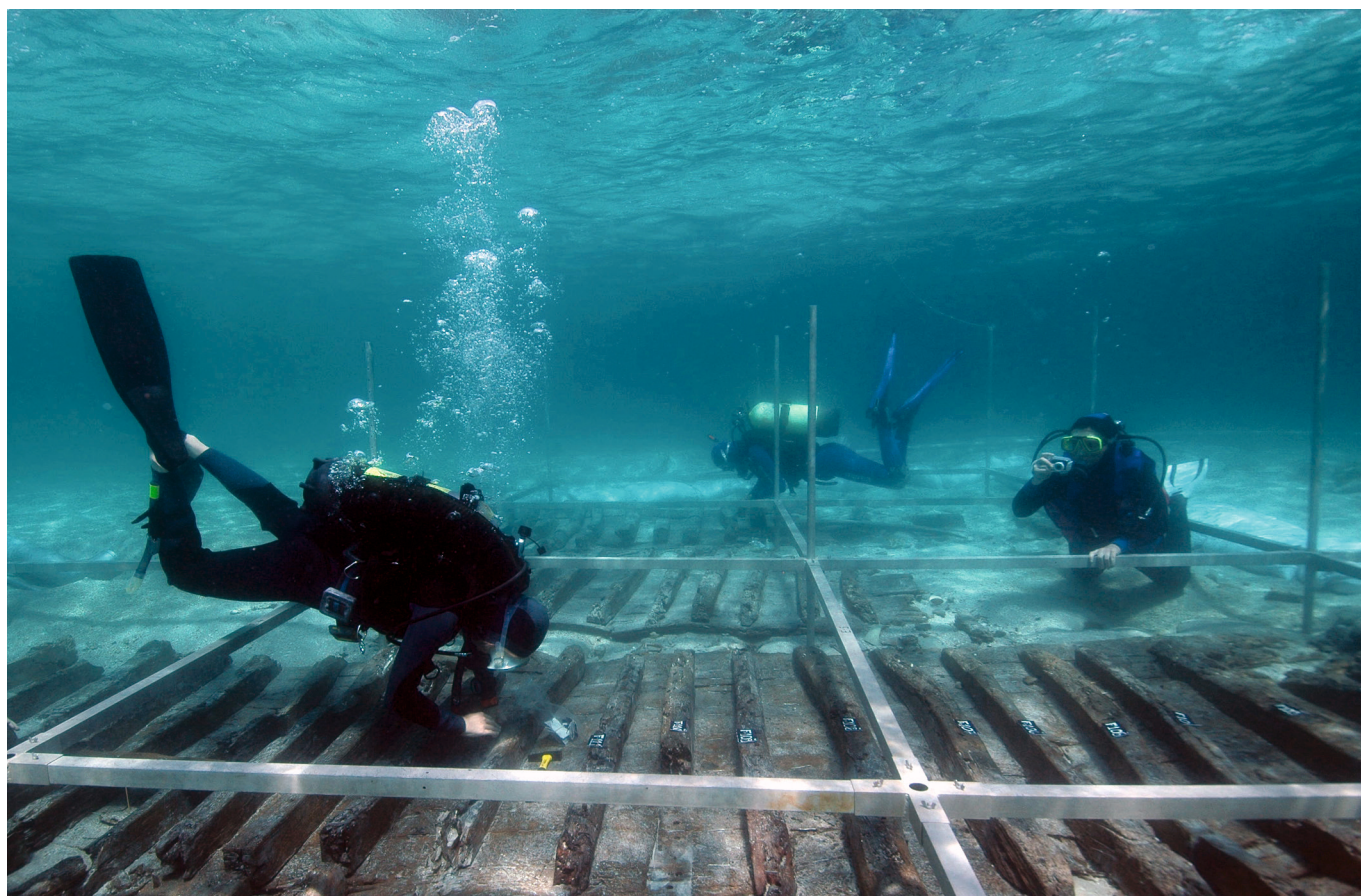

Sl. 4. / FIG. 4.

Istraživanje kasnoantičkog broda u Pakoštanima 2007. (foto: Ph. Groscaux).

Research of the Late Roman shipwreck in Pakoštane, 2007 (photo: Ph. Groscaux).

¹⁹ Više o istraživanju u poglavlju 3.5.2.

¹⁹ For more about the excavation, see chapter 3.5.2.

Već početni dani istraživanja ukazali su na potrebu hitne izrade osnovne terminologije na hrvatskom jeziku koja će omogućiti pisanje stručnih izvješća i preliminarnih objava nalaza te jednoobrazno prevođenje svih stranih termina koji su se koristili u svakodnevnoj komunikaciji među članovima međunarodne istraživačke ekipe.

Riječ je prije svega o nizu termina kojima se imenuju sastavni dijelovi i osnovne tehnike izrade brodske konstrukcije, bez kojih nije moguće opisati niti jedan detaljno istražen nalaz broda niti prevesti na hrvatski jezik stručnu literaturu. Osim toga, potrebno je raspolagati i nazivima za brodsku opremu, koja se također pronalazi uz ostatke broda ili se raspoznaju mjesta na kojima se ona nekada nalazila.

U skupinu neophodnih termina valja ubrojiti i niz izraza kojima se imenuju postupci brodograditelja prilikom izgradnje i održavanja broda, alati koji se pri tome koriste, a također i osnovni manevri. Kako je riječ o vrlo složenome poslu koji službena hrvatska leksikografija nije do danas riješila, u ovome radu ograničavam se na prijedlog rješavanja prvoga dijela problema, neophodnog za provođenje arheoloških istraživanja u domeni arheologije broda te komuniciranja rezultata takvih istraživanja.

3.1. Standardizacija hrvatske pomorske terminologije

Da terminologiju drvenoga broda nije jednostavno standardizirati ni u jednome jeziku, jasno je iz uvodnog poglavlja knjige koju je u formi priručnika za dokumentiranje i proučavanje brodskih konstrukcija objavio Richard Steffy.²⁰ U poglavlju o terminologiji autor tumači zbog čega se kao standard ne može iskoristiti samo jedan pomorski rječnik, neovisno o njegovom obimu i kvaliteti. Brodovi i brodice koje proučavamo pripadaju stotinama i tisućama godina, bezbrojnim tipovima i milijunima brodograditelja, koji su svaki na svoj način i prema svojim trenutnim potrebama imenovali sastavne dijelove brodske konstrukcije. Rječnici kojima raspolažemo u pravilu su vezani uz određeni kronološki i geografski prostor, pa od njih ne treba očekivati odgovore na sva pitanja. Gledano iz arheološke perspektive, može se dogoditi da se na ostacima brodova,

From the first days of the campaign, it became apparent that there was an urgent need to compile basic terminology in Croatian to enable professional reports to be written, and preliminary finds to be published, as well as to provide translations of all the foreign terms used in everyday communication between the members of the international excavation team.

These were primarily terms denoting the constituent parts of ships or basic ship construction techniques, without which it is not possible to describe any ship find in detail or to translate professional literature into Croatian. In addition, it was necessary to have appropriate Croatian names for the ship's equipment found with ship remains, or for the missing equipment whose original location it was possible to identify.

Another subcategory of necessary terminology concerns the various terms denoting the processes used by shipbuilders during ship construction and maintenance, the tools used for these processes, as well as basic sailing manoeuvres. As this is a very complex task that has not yet been accomplished by official Croatian lexicographers, in this paper I shall restrict myself to the attempt of solving the first part of the problem, which is necessary for conducting nautical archaeology campaigns in the field, and for communicating their results.

3.1. Standardisation of Croatian maritime terminology

It is by no means a simple task to standardise wooden boat terminology in any language. It is evident from the introductory chapter of a book published by Richard Steffy as a manual for documenting and studying ship construction.²⁰ In the chapter on terminology, Steffy explains why it is not possible to use only one maritime dictionary as a standard, irrespective of its size and quality. The ships and boats that we study cover thousands of years, countless ship types and millions of shipbuilders, who used different names for the constituent parts of the ship's construction according to their own specific needs. The dictionaries that we have are always associated with a certain chronological period and geographic area. Therefore, one should not expect them to provide the answer to all our questions. From an archaeological perspective, it is possible that among the ship

20 R. J. STEFFY, 2006 (1994), 6.

20 R. J. STEFFY, 2006 (1994), 6.

iz vremena koja prethode pisanim svjedočanstvima ili njima oskudijevaju, uoče detalji koji u postojećim rječnicima nisu imenovani. U tome slučaju, predlaže Steffy, valja izmisliti odgovarajuće termine koristeći na mudar način one već postojeće.²¹

Hrvatskoj pomorskoj terminologiji još se uvijek pristupa na različite načine, od apsolutne podrške lokalnim izrazima do dosljedne primjene tzv. hrvatskog nazivlja. Dijalektizmi različitoga podrijetla sastavni su dio svakodnevnoga govora stanovnika hrvatskog Jadrana i u proučavanju pomorske prošlosti neophodno ih je poznavati zbog razumijevanja lokalnoga usmenog i pismenog izražavanja. U određenom jezičnom sustavu oni vrlo precizno izriču sve što je potrebno kako bi se opisala cjelina drvenoga broda, ali su pri tome izrazito teritorijalno ograničeni te ih drugi jezični sustavi ne moraju nužno prepoznati.²² Dijalektizmi znatno variraju od mjesta do mjesta, pa se istim sadržajima ponekad pridjeljuje različito²³ ili se pak različitim sadržajima pridjeljuje isto ime²⁴. Stoga oni nisu prikladni za korištenje u znanstvenoj obradi rezultata arheoloških istraživanja jer bi se već prisutna nepreciznost njihovom primjenom još više povećala. Neprikladnost takvih termina očituje se i u činjenici da se oni u pravilu odnose na određene tipove tradicijskih plovila koji se i danas koriste, pa ne moraju nužno odgovarati elementima brodske konstrukcije i opreme koji su nam se očuvali iz prošlih vremena. Ovim se zaključcima ne nastoji umanjiti neprijeporna vrijednost dijalektizama unutar hrvatske pomorske jezične baštine koju je svakako potrebno očuvati sustavnim prikupljanjem i obradom prikupljenog materijala, ali se nastoji upozoriti na neophodnost korištenja jedinstvene hrvatske terminologije koja je, iako još uvijek nestandardizirana i nedovoljno prisutna u svakodnevnom govoru, primijenjena u mnogim pomorskim publikacijama.

remains from periods before written sources, or for which only scarce written sources exist, there are recognisable details which are not included in existing dictionaries. Steffy proposes that in such instances appropriate terms need to be invented, wisely exploiting those that already exist.²¹

There are multiple approaches to Croatian maritime terminology: from one in favour of local expressions, to one in favour of the consistent use of so-called Croatian terminology. Dialectal terms of different origins form a constituent part of the everyday language of the inhabitants of the Croatian Adriatic, and knowing them is indispensable in the study of maritime history, in order to understand local spoken and written communication. As part of a defined language system, they precisely denote everything that is necessary to describe the integrity of a wooden ship, but at the same time they are territorially restricted, and not necessarily recognised in other language systems.²² Dialectal expressions vary significantly from place to place, and sometimes the same elements bear different names²³ or, on the other hand, different elements bear the same name.²⁴ Obviously, both situations would be inappropriate in scholarly publications of the results of archaeological campaigns, and their use would further compound their inherent imprecision. The inappropriateness of such terms is evident also from the fact that these terms relate to certain types of traditional sailing vessels that are still in use, and as a result the terms do not necessarily correspond to ship construction and equipment elements that have been preserved from earlier periods. These conclusions are not intended to reduce the unquestionable value of dialectal terms in Croatian maritime language heritage, and they should certainly be preserved by systematically collecting and analysing them. However, they underline the need for a single Croatian terminology which, although still not standardised, and although not widely present in everyday language, could be used in many maritime publications.

21 R. J. STEFFY, 2006 (1994), 7.

22 Usp. G. FILIPI, 1997.

23 Usp. npr. nazive za produžnik koji se u Betini i Korčuli naziva *capul*, a u Krilu Jesenice *kriva glava* ili nazive za dokobiličnu platicu koja se u Betini naziva *picun*, a u Krilu Jesenice *panižel*.

24 Usp. npr. naziv *korba* koji u Betini označuje čitavo rebro, a u Krilu Jesenice samo rebrenicu.

21 R. J. STEFFY, 2006 (1994), 7.

22 Cf. G. FILIPI, 1997.

23 Compare, for example, the names used for a futtock (*produžnik*), which in Betina and Korčula is called *capul*, and in Krilo Jesenice *kriva glava*, or the names for a garboard strake (*dokobilična platica*), which in Betina is called *picun*, and in Krilo Jesenice *panižel*.

24 Compare, for example, the term *korba*, which in Betina denotes an entire frame (*rebro*), while in Krilo Jesenice it stands for floor timber (*rebrenica*).

Podrijetlo i povijest stvaranja hrvatske pomorske terminologije sustavno je prikazana u više radova.²⁵ Diana Stolac posebnu je pozornost posvetila hrvatskom pomorskom piscu i leksikografu Boži Babiću čiji su termini, prema njezinim riječima, osnova hrvatskoga pomorskog nazivlja.²⁶ Njegov se *Morski rječnik*²⁷ navodi kao prvi hrvatski pomorski rječnik²⁸ koji je hrvatskoj pomorskoj leksikografiji osigurao dugu tradiciju, dostojnu razine razvijenih pomorskih zemalja.²⁹ I u kasnijim tekstovima Babić je koristio i razradio hrvatsku pomorsku terminologiju,³⁰ a njegov je leksikografski rad kulminirao 1901. godine djelom *Pomorski rječnik ili nazivlje za brodarenje po moru*.³¹ Stvarajući hrvatsko tehničko i znanstveno nazivlje, on je tvorio nove riječi ili je lokalne i dijalektalne izraze fonološki i morfološki prilagođavao hrvatskom jeziku.³² Po pitanju uvođenja novih riječi u svakodnevnu uporabu, Babić je zapisao „(...) jer rieči treba da idu od usta do usta, pa kad proživu svoje vrieme, prihvatit, ukorienit će se za cielo u najboljem obliku i slogu”³³ očigledno uvjeren kako se intenzivnim korištenjem primjerenih termina može osigurati njihovo prihvaćanje.

Radovan Vidović u *Pomorskom rječniku* tiskanom 1984. godine svojim je pristupom visoko vrjednovao Babićevo djelo, a spomenuti povijesni pregled Dijane Stolac pokazao je kako su hrvatski pomorski termini prisutni od samoga početka hrvatske leksikografije.

Veliki pobornici hrvatske terminologije tijekom druge polovice dvadesetoga stoljeća bili su uvaženi profesori na Pomorskim fakultetima u Rijeci i Splitu te Fakultetu strojarstva i brodogradnje u Zagrebu, koji su u vlastitim radovima i prijevodima stranih publikacija dosljedno koristili hrvatske nazive za elemente brodskih konstrukcija. Usprkos njihovu nastojanju, te nastojanju njihove

The evolution of Croatian maritime terminology has been systematically presented in several papers.²⁵ Diana Stolac has devoted particular attention to the Croatian maritime author and lexicographer Božo Babić, whose terms, in her words, form the basis of Croatian maritime terminology.²⁶ His *Morski rječnik*²⁷ (*Marine Dictionary*) is considered to be the first Croatian maritime dictionary,²⁸ and provides Croatian maritime lexicography with a tradition worthy of developed maritime nations.²⁹ In his later work, Babić continued to use and develop Croatian maritime terminology,³⁰ and his lexicographical activities culminated in 1901 in his *Pomorski rječnik ili nazivlje za brodarenje po moru* (*A Maritime Dictionary or Seafaring Terminology*).³¹ In producing Croatian technical and scientific terminology, he coined new words or adjusted local and dialectal expressions to standard Croatian in terms of phonology and morphology.³² On introducing new words into the everyday language, Babić wrote: “words need to go from mouth to mouth, and after having bided their time, they become accepted and take root in their best form and style”³³. This demonstrates his conviction that more extensive use of appropriate terms would ensure their acceptance.

In his *Pomorski rječnik* (*Maritime Dictionary*) printed in 1984, Radovan Vidović highly praised Babić's work, and the abovementioned historical overview by Diana Stolac has shown that Croatian maritime terminology has been present from the beginnings of Croatian lexicography.

Great supporters of the Croatian terminology, in the course of the second half of the twentieth century, were the academics at the Faculties of Maritime Studies in Rijeka and Split, as well as at the Faculty of Mechanical Engineering and Naval Architecture in Zagreb, who in their own works and translations of foreign publications used Croatian terms for ship

25 R. VIDOVIĆ, 1982; B. PRITCHARD, 1993; B. PRITCHARD, 1997; D. STOLAC, 1998; T. DELIBAŠIĆ, 2001; Ž. STEPANIĆ, 2004; Ž. STEPANIĆ, 2011; M. BORUCINSKY, S. TOMINAC COSLOVICH, B. PRITCHARD, 2015. O pokušajima standardizacije nazivlja za potrebe arheologije vidi T. TEŽAK-GREGL, 2015.

26 D. STOLAC, 1998, 51.

27 B. BABIĆ, 1970.

28 Babićev rječnik tiskan je samo sedam godina nakon prvoga pomorskog rječnika na talijanskom jeziku. D. STOLAC, 1998, 9.

29 Ž. STEPANIĆ, 2005, 253.

30 B. BABIĆ, 1876; B. BABIĆ, 1877; B. BABIĆ, 1878.

31 B. BABIĆ, 1901.

32 D. STOLAC, 1998, 112-113.

33 B. BABIĆ, 1901, 4.

25 R. VIDOVIĆ, 1982; D. STOLAC, 1998; T. DELIBAŠIĆ, 2001; Ž. STEPANIĆ, 2004; Ž. STEPANIĆ, 2011; M. BORUCINSKY, S. TOMINAC COSLOVICH, B. PRITCHARD, 2015. On attempts to standardise terminology for the purpose of archaeology, see T. TEŽAK-GREGL, 2015.

26 D. STOLAC, 1998, 51.

27 B. BABIĆ, 1970.

28 Babić's dictionary was printed only seven years after the first maritime dictionary in Italian. D. STOLAC, 1998, 9.

29 Ž. STEPANIĆ, 2005, 253.

30 B. BABIĆ, 1876; B. BABIĆ, 1877; B. BABIĆ, 1878.

31 B. BABIĆ, 1901.

32 D. STOLAC, 1998, 112-113.

33 B. BABIĆ, 1901, 4.

vih nasljednika, hrvatska pomorska terminologija, uz izuzetak manjeg broja termina, još uvijek nije standardizirana.

3.2. Prijedlog osnovne terminologije za potrebe arheologije broda (Sl. 5-12)

U vrijeme dok je na Fakultetu strojarstva i brodogradnje još postojao predmet *Drvena brodogradnja*, Teodor Bernardi napisao je udžbenik *Konstrukcija drvenih brodova* koji je u ovome radu poslužio kao osnova za pripremanje početnog pojmovnika za potrebe arheologije broda.³⁴ Bernardijeva podjela u nešto je izmijenjenoj varijanti bila osnovom za izradu pojmovnika. Zadržana je podjela na uzdužne i poprečne građevne elemente trupa, ali su oplata i paluba izdvojeni kao zasebne cjeline, a podnica izdvojena u skupinu termina koji se odnose na potpalublje. Izdvajanje

construction elements. However, despite their efforts, and the efforts of their successors, Croatian maritime terminology, with the exception of a small number of terms, has still not been standardised.

3.2. Proposed basic terminology for the needs of nautical archaeology (Figs. 5-12)

When the subject *Wooden shipbuilding* was still taught at the Faculty of Mechanical Engineering and Naval Architecture, Teodor Bernardi wrote a textbook *Wooden Ship Construction*, which was used in this paper as the basis for the preparation of an initial glossary for the needs of nautical archaeology.³⁴

A somewhat amended version of Bernardi's classification served as a basis for compiling this glossary. The division into longitudinal and transverse construction elements of the hull has been preserved, but the planking and the deck have been considered

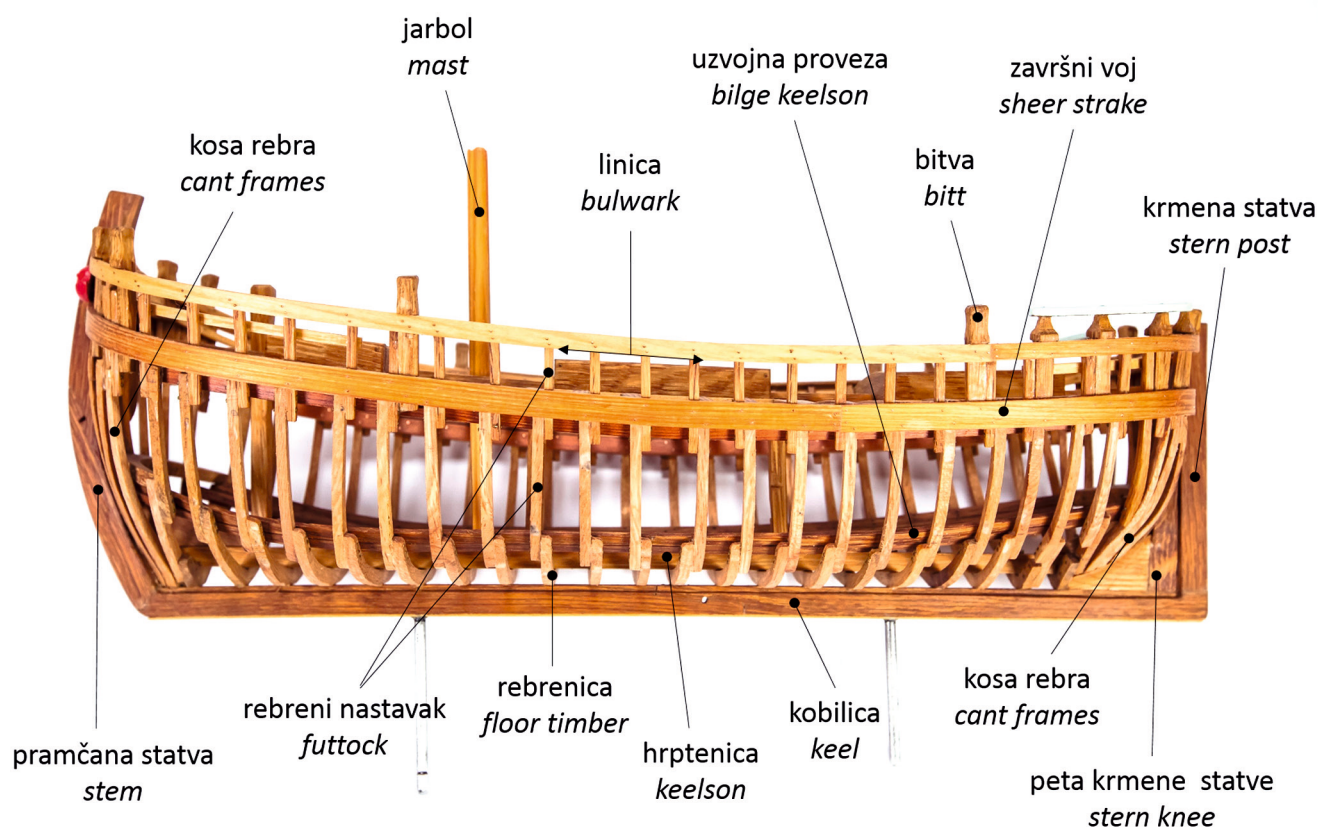

Sl. 5. / FIG. 5.

Studijski model konstrukcije bracere – lijevi bok (maketa: L. Keber; foto: E. Šilić), s prikazom odabranih termina.

Study model of the construction of bracera ship type – portside (model: L. Keber; photo: E. Šilić), with the representation of selected terms.

34 T. BERNARDI, 1964.

34 T. BERNARDI, 1964.

oplate u zasebnu cjelinu predložili su Patrice Pomey i Eric Rieth u već spomenutom priručniku o povijesti i suvremenim načelima arheologiji broda *L'archéologie navale*,³⁵ a takav pristup potvrdilo je i nekoliko hrvatskih brodograđevnih inženjera.³⁶ Iako oplata zbog uzdužnog protezanja platica na prvi pogled uistinu djeluje kao element uzdužne čvrstoće, ona ustvari optače elemente uzdužne i poprečne čvrstoće i čini ih nepropusnima. Funkcija oplata je višestruka, a dodatna čvrstoća koju brod njome dobiva ne može se definirati isključivo kao uzdužna. Kad je riječ o podnici, ona je u velikoj većini slučajeva mobilni element koji ne doprinosi čvrstoći broda pa se stoga ne može smatrati elementom uzdužne čvrstoće.

Osim Bernardijeva priručnika, pri izradi pojmovnika korištena je i *Pomorska enciklopedija*, Johowov *Priručnik za brodogradnju* u prijevodu grupe autora pod vodstvom Adama Armande, Vidovićev *Pomorski rječnik*, *Hrvatsko-engleski rječnik pomorskog nazivlja*, radovi Igora Belamarića i Luciana Kebera, te suvremeni rječnici hrvatskoga jezika.³⁷ Po savjetu Velimira Salamona, odabrani termini u velikoj su većini preuzeti iz Bernardijeva rada te upotpunjeni terminima iz drugih navedenih djela. Takav pristup bio je dijelom uvjetovan činjenicom da drvena brodogradnja više nije sastavni dio programa ni jednog studija s pomorskom tematikom u Hrvatskoj, pa ne postoji ni jedan noviji udžbenik iz kojega bi se moglo sustavno preuzeti sve potrebne termine. U navedenim radovima novijega datuma nalaze se većinom termini koji se odnose na suvremene brodove i koji se tek manjim dijelom mogu primijeniti na brodove uopće; u *Pomorskoj enciklopediji* nalazimo primjereni odabir termina, ali ih je daleko manje u usporedbi s Bernardijevim specijaliziranim priručnikom, a u suvremenim rječnicima hrvatskoga jezika izbor je termina izrazito ograničen. Osim toga, rječnici hrvatskog jezika prilično neujednačeno i nedosljedno tretiraju brodograđevne termine, pa ih nije moguće

as separate entities, while flooring has been isolated as a category of terms referring to the hold. Classifying planking as a separate unit was proposed by Patrice Pomey and Eric Rieth in their, already quoted handbook on the history and modern principles of nautical archaeology *L'archéologie navale*,³⁵ and such an approach has been confirmed by several Croatian shipbuilding engineers.³⁶ Although the longitudinal direction of planking suggests an element of longitudinal stiffness, it actually seals elements of longitudinal and transverse stiffness, making them impermeable. Planking is multifunctional, and the increased stiffness it provides the ship cannot be defined exclusively as longitudinal. As for flooring, in the vast majority of cases it is a non-integrated addition which does not contribute to the ship's stiffness, and therefore cannot be considered a longitudinal stiffness element.

Apart from Bernardi's textbook, the following literature was also used while working on the glossary: *A Maritime Encyclopaedia*; the Croatian translation of Johow's *Hilfsbuch für den Schiffbau*, translated by a group of authors led by Adam Armandy; Vidović's *A Maritime Dictionary*; *A Croatian-English Maritime Dictionary*; papers by Igor Belamarić and Luciano Keber, and contemporary dictionaries of Croatian.³⁷ Following Velimir Salamon's advice, the selected terms were largely taken from Bernardi's textbook, enriched by terms from the other aforementioned works. This approach was partly a result of the fact that wooden shipbuilding is not part of any maritime study programme in Croatia, and therefore there are no recent textbooks from which all the necessary terms could be systematically taken. The more recent abovementioned works mostly contain terms referring to modern ships, only a small part of which apply to ships in general. *A Maritime Encyclopaedia* provides an appropriate choice of terms, but their number is far smaller than in Bernardi's specialised textbook, while in modern Croatian dictionaries, the choice of terms is extraordinarily restricted. In addition, Croatian dictionaries treat shipbuilding no-

35 P. POMEY, E. RIETH, 2005, 25-28.

36 Zahvaljujem inženjerima brodogradnje Igoru Belamariću i Roku Markovini na velikoj pomoći pri odabira najprikladnijih termina i podjele termina u odgovarajuće skupine. Zahvaljujem također Vladimiru Skračiću, Velimiru Salamonu, Lucianu Keberu i Karlu Klimanu. Njihova mi je pomoć pri odabiru, razvrstavanju i definiranju termina bila iznimno vrijedna i korisna.

37 POMORSKA ENCIKLOPEDIJA, 1960; R. VIDOVIĆ, 1984; B. PRIČARD *et al.* 1991; J. BELAMARIĆ, 2002; J. BELAMARIĆ, 2005; J. BELAMARIĆ, 2006; L. KEBER, 2013; J. ŠONJE, 2000; *HER*, 2002; J. ANIĆ, 2004; LJ. JOJIĆ, 2015.

35 P. POMEY, E. RIETH, 2005, 25-28.

36 I would like to thank the naval architects and marine engineers Igor Belamarić and Roko Markovina for their great help in selecting the most suitable terms and classifying them in corresponding categories. I would also like to thank Vladimir Skračić, Velimir Salamon, Luciano Keber and Karlo Kliman. Their help in selecting, classifying and defining terms was extraordinarily valuable and useful.

37 POMORSKA ENCIKLOPEDIJA, ("A Maritime Encyclopaedia") 1960; R. VIDOVIĆ, 1984; B. PRIČARD *et al.* 1991; J. BELAMARIĆ, 2002; J. BELAMARIĆ, 2005; J. BELAMARIĆ, 2006; L. KEBER, 2013; J. ŠONJE, 2000; *HER* (A Croatian-English Dictionary), 2002; J. ANIĆ, 2004; LJ. JOJIĆ, 2015.

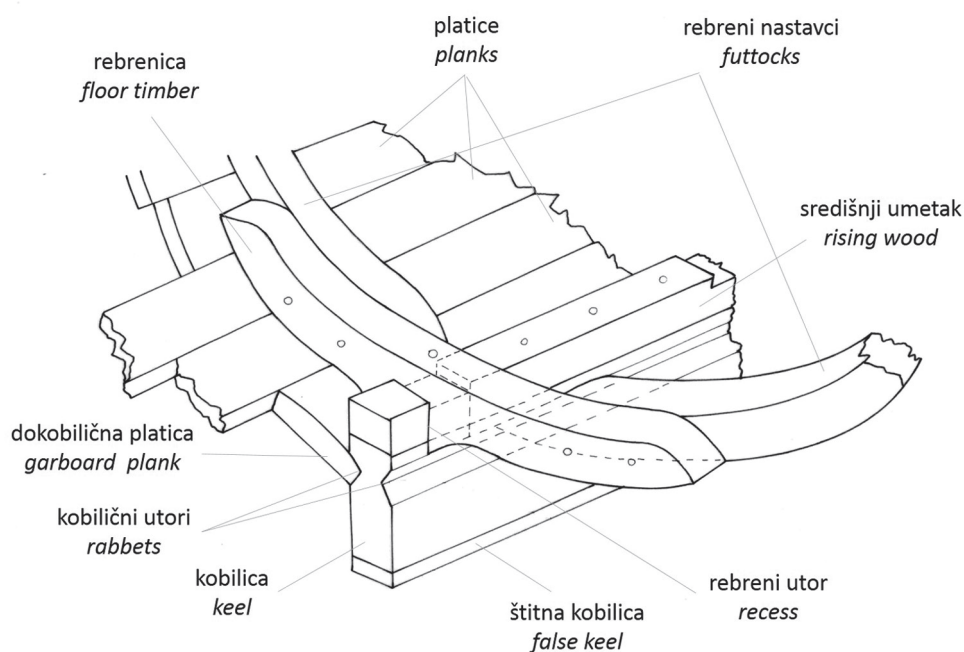

SL. 6. / FIG. 6.

Aksonometrijski prikaz dijela kobilice s oplatom, rebrenicom i rebrenim nastavcima.

Axonometric representation of a detail of the keel, with planking, floortimber and futtocks.

iskoristiti za sustavnu izradu pojmovnika. Teškoće s korištenjem takve literature jasno ilustrira jednostavan primjer široko prihvaćenog naziva *platica* za dasku koja je sastavni dio brodske oplate. Od tri konzultirana rječnika,³⁸ pojam i njegovo objašnjenje nalazi se samo u jednome³⁹, dok je u ostala dva on u potpunosti izostao⁴⁰.

Pojam *šuperiti*, koji je također široko prihvaćen, objašnjen je u rječnicima na dva različita načina. U jednom slučaju njegovo značenje uglavnom odgovara pojmu *kalafatati* koji se njime zamjenjuje, uz sljedeće objašnjenje: „vodonepropusno brtviti sljubnice i stikove nabijanjem šuperiva između platica ili trenica drvena trupa“.⁴¹ U druga dva slučaja pojmu se pripisuje značenje “zatvarati smolom, blatom ili sličnim ljepljivim sredstvom rupu ili pukotinu”, što ne odgovara u potpunosti brodograđevnom značenju pojma o kojem je riječ.⁴² Spajanjem i dopunom oba objašnjenja dobiva se značenje riječi kakvo mu pripisuju drugi svjetski jezici, koji njime opisuju sve postupke brtvljenja pukotina i spojeva kućinom te premazivanja brod-

menclature rather unevenly and inconsistently, which makes them unsuitable for compiling a glossary. The difficulties in using such literature are clearly illustrated by a simple example of the widely accepted term *platica* for a plank as part of a ship's planking. Three dictionaries were consulted,³⁸ but the term and its explanation were only found in one,³⁹ while the remaining two completely omitted it.⁴⁰

Another widely accepted term, *šuperiti* (“to caulk”), is explained in the dictionaries in two different ways. In one case, its meaning mostly overlaps with the cross-referenced term *kalafatati* (“to caulk, to lute”), for which the following explanation is given: “to make the seams and joints watertight by compressing caulk between the planks or strakes of a wooden hull.”⁴¹ In the two other cases, the meaning of the term is described as “to close a hole or a crack with pitch, mud or other similar sticky agent”, which does not fully correspond with the term's meaning in shipbuilding.⁴² By combining the two explanations and expanding them, the concept acquires the meaning it has in other world languages, denoting all

38 J. ŠONJE, 2000; HER, 2002; M. ANIĆ, 2004.

39 J. ŠONJE, 2000.

40 HER, 2002; M. ANIĆ, 2004.

41 J. ŠONJE, 2000.

42 HER, 2002; M. ANIĆ, 2004.

38 J. ŠONJE, 2000; HER, 2002; M. ANIĆ, 2004.

39 J. ŠONJE, 2000.

40 HER, 2002; M. ANIĆ, 2004.

41 J. ŠONJE, 2000.

42 HER, 2002; M. ANIĆ, 2004.

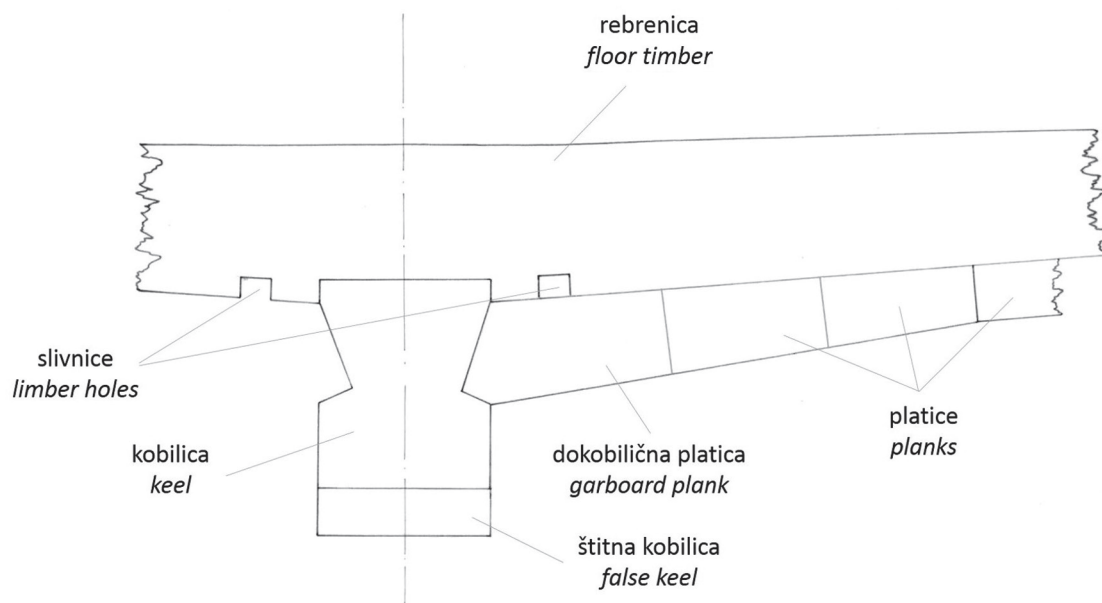

Sl. 7. / FIG. 7.

Detalj kobilice s rebrenicom (prema T. BERNARDI, 1964, Sl. 101).

Detail of keel and floortimber (after T. BERNARDI, 1964, Fig. 101).

skog trupa smolom radi postizanja nepropusnosti brodske konstrukcije.

Tek u *Velikom rječniku hrvatskog standardnog jezika*, koji je nedavno izašao iz tiska, nalazimo većinu termina koje koristi brodograđevna literatura, te priličan broj termina koji su se do sada ubrajali u narodni govor (vidi tablicu termina u prilogu). Zahvaljujući takvom pristupu, termin *kalafatati* dobio je svoje mjesto u rječniku, uz objašnjenje „stupom popunjavati sljubnice ili kimente“, a termin *šuperiti* po pitanju objašnjenja preusmjerava nas na onaj prethodni.⁴³ Zanimljivo je, međutim, kako u rječniku nisu našli mjesta termini poput *voj* ili *lakomica* (vidi tablicu u prilogu), koji se koriste kako u hrvatskom govornom jeziku, tako i u brodograđevnoj literaturi.

Navedeni primjeri samo su ilustracija teškog zadatka koji se postavlja pri odabiru odgovarajućih hrvatskih termina, te nas upozoravaju na mogućnost da se u budućnosti, zbog neprovedene standardizacije, pojave i novi prijedlozi. Uspriješ problemima, razvoj arheološke znanosti navodi na odabir nužne skupine termina koja se može primijeniti na brodogradnju u prošlosti jer, kao što je rečeno, bez njih na hrvatskom jeziku nije moguće izraziti složene rezultate novih istraživanja. U tu

forms of sealing seams and joints with oakum, and coating the ship's hull with pitch in order to obtain a waterproof ship structure.

It is only in the recently published *Veliki rječnik hrvatskog standardnog jezika* (*The Great Dictionary of Standard Croatian*) that the majority of terms used in shipbuilding literature are found, together with a rather large number of regionalisms (see Table 1 in the appendix). Thanks to this approach, the term *kalafatati* has an entry in the dictionary with the definition “to fill in seams with hemp”, and is cross-referenced to the term *šuperiti*.⁴³ However, it is interesting that terms such as *voj* or *lakomica* (see Table in the appendix), which are used both in spoken Croatian and in shipbuilding literature, have not been included in the dictionary.

These examples are intended merely as an illustration of the difficult task with which one is confronted when selecting appropriate Croatian terms, and to warn us of the possibility that in the future, due to a lack of standardisation, new proposals might appear. Despite the problems involved, the advancement of archaeology requires the selection of terms to describe historical shipbuilding. If not, as has already been stated, the Croatian language will not be able to describe the complex results of the ongoing archaeo-

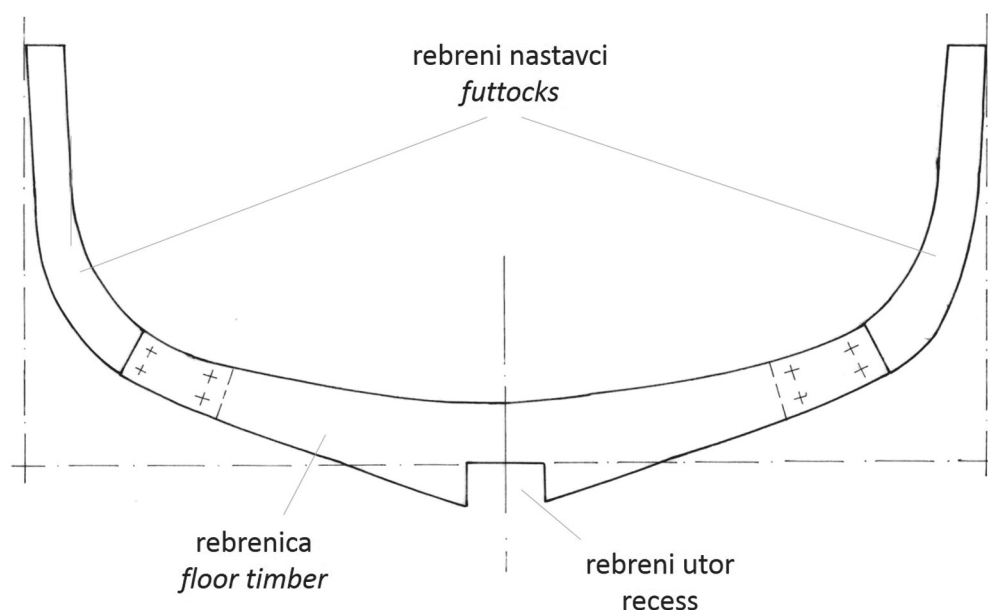

SL. 8. / FIG. 8.

Brodsko rebro (prema T. BERNARDI, 1964, Sl. 54).

Ship frame (after T. BERNARDI, 1964, Fig. 54).

su skupinu prije svega uključeni opći termini koji se odnose na brod, elementi brodske konstrukcije, elementi za spajanje, nazivi spojeva i tehnike spajanja, oprema broda te materijali i postupci vezani uz zaštitu i održavanje, tj. sve ono što je nužno kako bi se kvalitetno opisala evidencija na koju nailazimo u slučaju arheološkog otkrića broda. Termini koji su uvršteni u pojmovnik ne moraju se nužno odnositi na očuvane elemente brodske konstrukcije i brodograđevne tehnike, već i na one koji nedostaju jer su podlegli zubu vremena ili nas njihova odsutnost navodi na određene zaključke. Zbog obima i organizacije građe pojmovnik je iznesen u Tablici 1, a obuhvaća sljedeće podskupine:

1. Osnovni pojmovi
2. Uzdužni građevni elementi trupa
3. Poprečni građevni elementi trupa
4. Oplata trupa
5. Paluba i potpalublje
6. Dodatni ukrasni i funkcionalni elementi
7. Elementi za spajanje, spojevi i tehnike
8. Zaštita i održavanje
9. Oprema
10. Alat.

logical research. This includes, in the first place, general ship-related terms, ship construction elements, joint elements, joining elements and techniques, ship equipment, and materials and processes associated with protection and maintenance - in short, everything that is necessary for a good description of ship excavations. The terms selected for the glossary are not only used to denote preserved ship construction elements or specific shipbuilding techniques, but also the elements that are missing as a result of natural decay, or whose absence can lead us to certain conclusions. Because of the volume and organisation of the material, the glossary is shown in Table 1, and comprises the following subcategories:

1. Basic terms;
2. Longitudinal construction elements of the hull;
3. Transversal construction elements of the hull;
4. Planking of the hull;
5. Deck and hold;
6. Additional decorative and functional elements;
7. Joint elements, joints and techniques;
8. Protection and maintenance;
9. Equipment;
10. Tools.

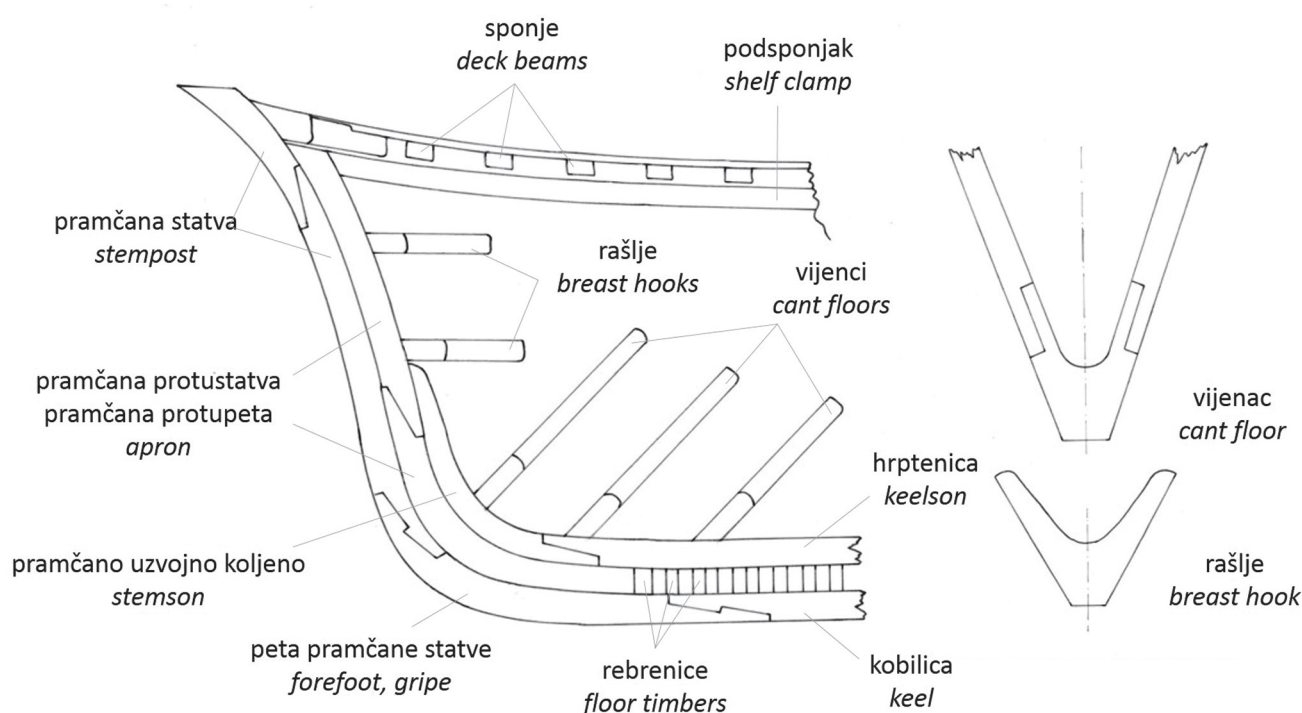

SL. 9. / FIG. 9.

Uzdužni presjek pramčanog dijela broda (prema T. BERNARDI, 1964, Sl. 130-132).

Longitudinal section of the bow (after T. BERNARDI, 1964, Fig. 130-132).

Navedene skupine rezultat su pokušaja klasifikacije najužeg odabira termina potrebnih za stručnu obradu ostataka brodova prošlih vremena, poglavito onih iz prapovijesnog i antičkog doba,⁴⁴ uključivo elemente brodske konstrukcije i opreme, tehnike izrade i održavanje broda. Termini u njima ne redaju se abecednim redom već nastoje slijediti logiku razmišljanja o brodskoj konstrukciji. Kako ni u jednoj podskupini broj odabranih termina ne prelazi 25, takav pristup nije poseban problem jer se u tablicama može brzo i lako snaći svatko tko traži odgovarajući termin za pojedini konstruktivni element, predmet ili postupak. Prijeko potreban abecedni red nadoknađen je abecednim popisom termina u Tablici 2, u kojemu je uz svaki termin brojem označeno njegovo mjesto u Tablici 1, pa mu se može ući u trag ukoliko se poznaje sam termin, ali ne i pravo značenje ili ekvivalent u engleskom jeziku.

Prvi stupac tablice sadrži potpuno ili uglavnom prihvaćen hrvatski termin. U drugome stupcu nalazi se kratko objašnjenje i narodni naziv, najčešće preuzet iz knjige Gorana Filipija *Betinska brodogradnja*;

The categories are the result of an attempted classification of a small selection of terms necessary for the professional study of historical ship remains, particularly those from the ancient periods,⁴⁴ including elements of ship's hull and equipment, construction and maintenance techniques. The terms are not arranged in alphabetical order but follow the logic of a ship's structure. Since none of the subcategories contains more than 25 items, this approach does not cause problems, as anyone looking for an appropriate term for an individual structural element, object or process can rapidly and easily navigate the tables. The much needed alphabetical order has been provided by an alphabetical list of terms in Table 2, where a number next to each term indicates its position in Table 1. In that way it is possible to find easily a word if one is familiar with the term itself, but not with its actual meaning or equivalent in English.

The first column of the table contains a completely or widely accepted Croatian term. The second column contains a short explanation and other common term(s), most frequently taken from Goran Filipi's book *Betinska brodogradnja*, *Etimologijski rječnik*

⁴⁴ Brodovi iz kasnijih vremena daleko su složeniji od svojih prethodnika.

⁴⁴ Ships from later periods are far more complex than their predecessors.

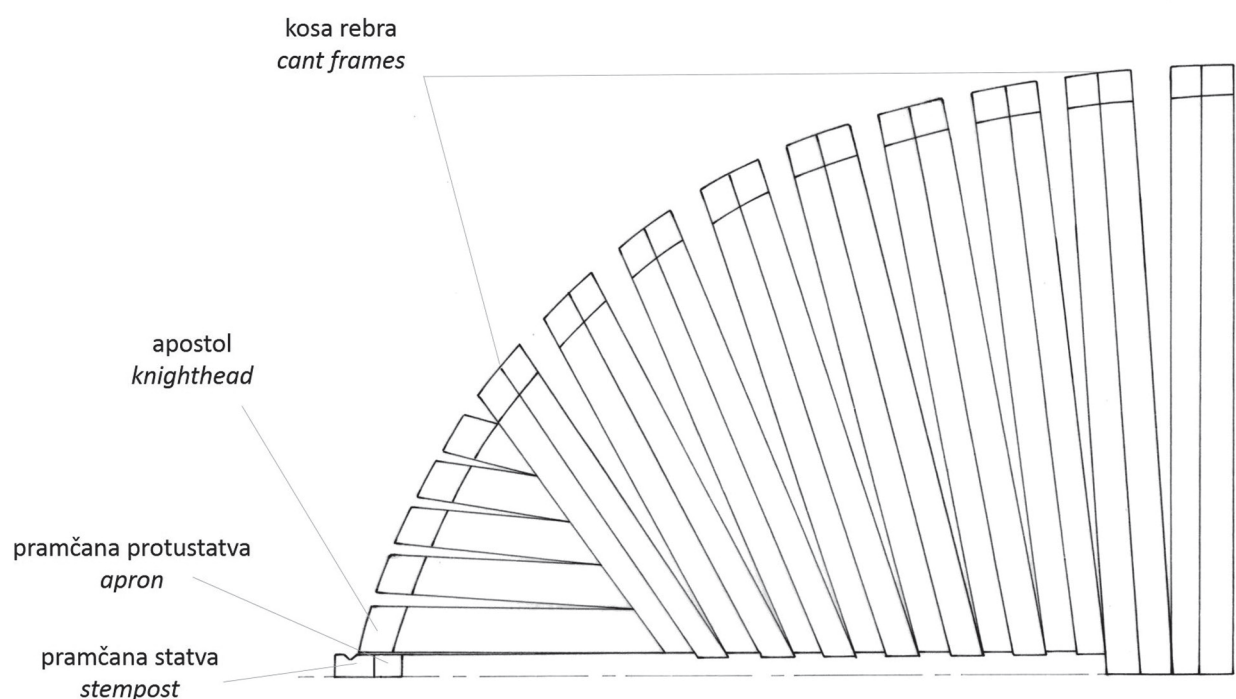

SL. 10. / FIG. 10.

Tlocrt rebara u pramčanom dijelu broda (prema R. STEFFY, 1994, 294, Fig. G-13).

Top view of the frames in the bow (after R. STEFFY, 1994, 294, Fig. G-13).

Etimologijski rječnik pučkog nazivlja kao jedinog rječnika narodnog nazivlja isključivo brodograđevnog sadržaja koji je do danas tiskan u Hrvatskoj.⁴⁵ Narodnih bi se naziva u mnogim slučajevima moglo navesti i više jer se oni uglavnom manje ili više razlikuju na različitim jadranskim prostorima. U nekim slučajevima riječ je o inačici naziva istoga podrijetla, dok se u drugim slučajevima mogu očekivati i velike razlike. Kako nas posao na terminologiji za potrebe arheologije broda i plovidbe ne bi odveo predaleko u problematiku hrvatske pomorske terminologije, Filipijev rječnik koristi se kao glavni izvor za sve termine koji su u njemu našli svoje mjesto. Ostali su termini uvršteni na osnovi radova Vladimira Skračića,⁴⁶ Roka Markovine i Tončija Ukalovića⁴⁷ te usmenih podataka dobivenih od stručnjaka za drvenu brodogradnju i majstora na području Betine i Murtera, Korčule i Krila Jesenica.

U trećem stupcu tablice uvršteni su odgovarajući termini na engleskom jeziku. Engleski su termini najčešće prisutni u stručnoj literaturi, a koriste ih znanstvenici iz čitavog svijeta jer je na verificiranim

pučkog nazivlja, (*Shipbuilding of Betina: An Etymological Dictionary of Vernacular Terms*), which is the only Croatian dictionary published to date that contains vernacular shipbuilding terms.⁴⁵ In many cases, other common terms could have been stated as well, as there are differences in various parts of the Adriatic. In some cases, there are variants of names of the same origin, while in other cases large differences can be expected. To avoid the work on nautical archaeology terminology becoming too deeply involved in regional Croatian maritime terminology, Filipi's dictionary has been used as the main source for all terms included. Other terms were selected based on papers by Vladimir Skračić,⁴⁶ Roko Markovina, and Tonči Ukalović,⁴⁷ as well as data obtained in the field from wooden shipbuilding experts and craftsmen in the areas of Betina and Murter, Korčula, and Krila Jesenica.

The remaining column of the table contains the corresponding terms in English. The terms most frequently used in technical literature by researchers from across the world are English ones, since English

45 G. FILIPI, 1997.

46 V. SKRAČIĆ, 2003.

47 R. MARKOVINA, T. UKALOVIĆ, 2010.

45 G. FILIPI, 1997.

46 V. SKRAČIĆ, 2003.

47 R. MARKOVINA, T. UKALOVIĆ, 2010.

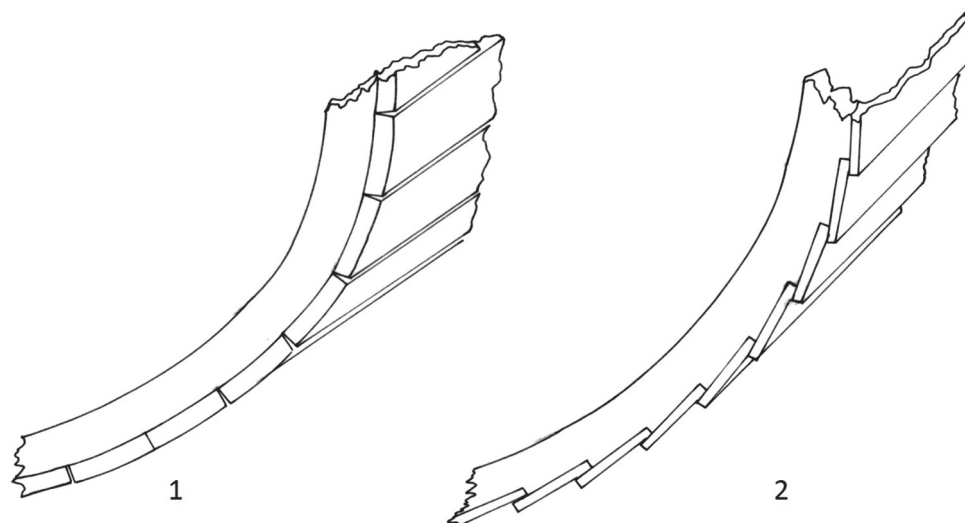

SL. 11. / FIG. 11.

Shematski prikaz stične ili sljubne (eng. *carvel*) i prijeklopne (eng. *clinker*) gradnje brodskog trupa.

Schematic representation of the carvel- and clinker-built hull.

međunarodnim arheološkim skupovima s tematičkom arheologije broda engleski uveden kao službeni jezik.⁴⁸ Osim engleskoga pomorskog rječnika⁴⁹ za prijevod termina na engleski jezik korištena su dva pojmovnika u radovima vodećih stručnjaka u području arheologije broda koja se najčešće koriste u struci te dva priručnika iz 19. i početka 20. stoljeća.⁵⁰ Termini na engleskom jeziku također su popisani po abecednome redu, čime se brzo i lako dolazi do njihova mjesta u pojmovniku.

Kao što je rečeno, u predloženome pojmovniku nalazi se tek uži izbor termina vezanih uz brod i brodogradnju, neophodnih za izricanje rezultata arheoloških istraživanja na hrvatskom jeziku. Hrvatski termini koji se ovim putem predlažu kao standard za hrvatsku arheološku literaturu preuzeti su iz navedenih brodograđevnih priručnika i prihvaćeni od strane hrvatskih brodograditelja. Oni još uvijek u većini slučajeva nisu standardizirani hrvatski izrazi koje možemo naći u svakom rječniku hrvatskoga jezika, ali činjenica da se koriste u suvremenoj brodograđevnoj literaturi dovoljna je kako bi se oprav-

is the official language in international archaeological conferences on nautical archaeology.⁴⁸ An English maritime dictionary,⁴⁹ two glossaries frequently used in this area from publications of leading experts in the field of nautical archaeology, and two handbooks from the 19th century and the beginning of the 20th century were used to translate terms into English.⁵⁰ There are also alphabetical lists for terms in all three foreign languages, thus enabling quick and simple access to them in the glossary.

As previously stated, the proposed glossary contains only a narrow selection of ship and shipbuilding-related terms necessary for describing the results of archaeological campaigns in Croatian. The Croatian terms proposed as a standard in Croatian archaeological literature were taken from the aforementioned shipbuilding handbooks and accepted by Croatian shipbuilders. In most cases, these are Croatian expressions that have still not been standardised and cannot be found in any Croatian dictionary. However, the fact that they are used in contemporary naval architecture literature is enough to justify

48 *International Symposium on Ship and Boat Archaeology* i *TROPIS – International Symposium on Ship Construction in Antiquity*.

49 C. W. T. LAYTON, 1973.

50 S. B. LUCE, 1891; R. M. VAN GAASBEEK, 1918; R. J. STEFFY, 1998; F. HOCKER, 1991.

48 *ISBSA – International Symposium on Ship and Boat Archaeology* and *TROPIS – International Symposium on Ship Construction in Antiquity*.

49 C. W. T. LAYTON, 1973.

50 S. B. LUCE, 1891; R. M. VAN GAASBEEK, 1918; R. J. STEFFY, 1998; F. HOCKER, 1991.

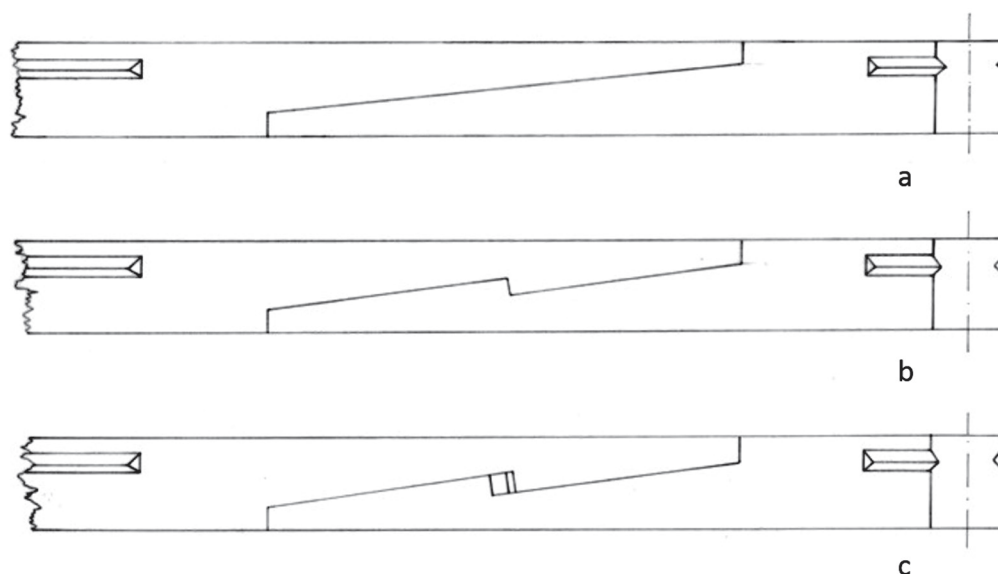

SL. 12. / FIG. 12.

Spojevi (ključevi): a) jednostavan ključ, b) ključ na zub i c) ključ na čep i kutiju, (prema T. BERNARDI, 1964, Sl. 15, 16, 18).

Scarfs: a) diagonal scarf, b) hook scarf and c) keyed hook scarf (after T. BERNARDI, 1964, Fig. 15, 16, 18).

dalo njihovo korištenje za proučavanje prošlosti brodogradnje kojom se bavi arheološka disciplina arheologije broda.

Iako je većina termina primjenjiva na današnje brodove, nekoliko izraza svojstveno je samo brodovima iz prošlih vremena. Riječ je, na primjer, o zasnivanju broda prema konceptu *prvo ljuska*, koji pretpostavlja kreiranje oplata u koju se naknadno umeću rebra, a time i dominantnu ulogu ljuske u brodskoj konstrukciji. Takav koncept na Mediteranu svojstven je brodovima prapovijesnog i antičkog doba, a zamjenjuje ga koncept *prvo kostur* koji se i danas primjenjuje u drvenoj brodogradnji.⁵¹ Za razliku od platica brodova zasnovanih prema konceptu *prvo kostur*, platice brodova zasnovanih prema konceptu *prvo ljuska* u pravilu su međusobno spojene tehnikom „šivanja“ ili sistemom utora i jezičaca koje se, sukladno današnjem konceptu, više ne koriste u mediteranskoj drvenoj brodogradnji.

U posljednjoj skupini termina zastupljen je alat za izradu, popravak i održavanje brodova. Većina alata koja se koristi u tradicijskoj drvenoj brodogradnji vuče svoje korijene iz daleke prošlosti.

their inclusion in studies of historical shipbuilding, which is the subject matter of nautical archaeology.

Although most terms can be applied to present-day ships, several expressions are characteristic only of ships from past periods. These are, for example, ships designed according to the *shell-first* concept, which assumes the assembly of planking into which frames are subsequently inserted, meaning that the shell plays a predominant role in the ship's structure. In the Mediterranean, such a concept is typical of ships from the prehistoric and Classical Antiquity times, but was later replaced by the *skeleton-first* concept, which has been applied in wooden shipbuilding up to the present.⁵¹ Unlike the planks of ships designed according to the *skeleton-first* concept, planks of ships designed according to the *shell-first* concept are usually joined by the technique of *sewing* or *lacing*, or by a system of mortise and tenon joints. These techniques are no longer used in modern Mediterranean wooden shipbuilding.

The final category of terms concerns ship construction, repair and maintenance tools. Most of the tools used in traditional wooden shipbuilding have

51 O arheološkim svjedočanstvima napuštanja koncepta *prvo ljuska* i primjene koncepta *prvo kostur* vidi P. POMEY, E. RIETH, Y. KAHANOV, 2013, gdje je navedena ostala relevantna literatura.

51 For archaeological testimonies on the abandonment of the *shell-first* concept in favour of the *skeleton-first* concept, see P. POMEY, E. RIETH, Y. KAHANOV, 2013, who also refer to other relevant literature.

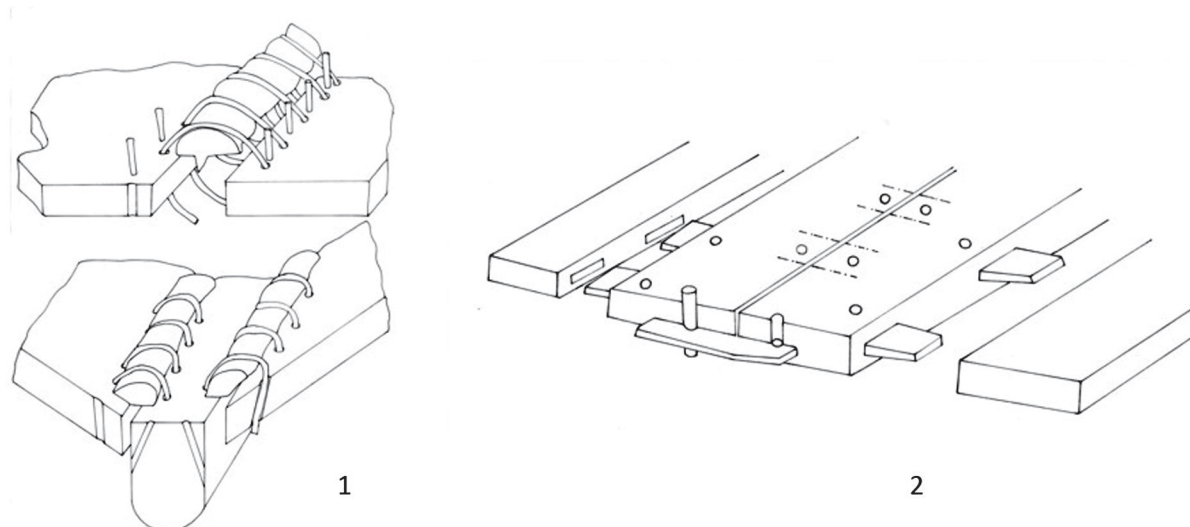

Sl. 13. / FIG. 13.

Spajanje uzdužnih elemenata brodske konstrukcije a) tehnikom 'šivanja', detalj (prema Z. BRUSIĆ, 1966) i b) tehnikom spajanja platica sistemom utora i jezičaca, detalj (prema P. POMEY, 2004).

Assembly of the longitudinal elements of the hull structure by 1) sewing/lacing technique, detail (after Z. BRUSIĆ, 1966) and b) system of mortise and tenon joints, detail (after P. POMEY, 2004).

Antički su alati ponekad prikazani na kamenim spomenicima ili se pronalaze u kontekstima arheoloških nalazišta. Najpoznatiji spomenik na kojemu se jasno razabire brodograđevni alat u svojoj funkciji ravenski je nalaz nadgrobne stele Publija Longidijena.⁵² Na njoj je prikazan *faber navalis* koji teslom obrađuje rebro kako bi ga prilagodio za umetanje u već gotov brodski trup. Tesla u njegovoj ruci naliči teslama koje se i danas koriste za obradu posječenog drva. Kao što im ime kaže, njima se drvo teše za razliku od sječenja koje se obavlja sjekirrom. Teško pristupačni dijelovi brodske konstrukcije obrađuju se alatkom zvanom *bradva*, koja je u odnosu na lagano zakrivljeni držak postavljena uzdužno, a ne poprečno poput tesle. Kako i bradva služi za tesanje, ona se ponekad miješa s teslom, iako ustvari naliči manjoj sjekiri.⁵³

Tragovi raznih alatki često se primjećuju na očuvanim drvenim dijelovima brodskih konstrukcija, a njihovo pomno bilježenje predstavlja neizostavan dio sustavnog proučavanja brodograđevnog procesa. Za detaljniju podjelu alatki i primjenu odgovarajućih naziva potrebno je provesti zasebnu studiju. Isto vrijedi i za niz postupaka u gradnji, popravku i održavanju broda koji su nam za sada terminološki nedovoljno poznati. Ukoliko se

their roots in the distant past. Ancient tools are sometimes represented on stone monuments or unearthed in archaeological contexts. The most famous monument in which shipbuilding tools are clearly recognizable is the funerary stela of Publius Longidienus in Ravenna.⁵² It depicts a *faber navalis* working a frame with a *shipwright's adze* in order to adjust it for insertion into a pre-constructed ship hull. The *shipwright's adze* in his hand is similar to adzes in use today to process cut wood. These are used for shaping wood, as opposed to cutting it, which is done with an *axe*. The parts of a ship's structure which are hard to access are worked with a tool called a *hatchet*, which has a blade set longitudinally, i.e. at right angles to its slightly curved shaft, in contrast to a *shipwright's adze* blade, which is set transversely, i.e. at right angles to the tool's shaft. As a *hatchet* is used in the particular way, it is sometimes confused with a *shipwright's adze*, although it looks more like a small axe.⁵³

Toolmarks are frequently noticed on the preserved wooden parts of ship structures, and their careful recording is an important part of any systematic study of the boatbuilding or shipbuilding process. For a more detailed classification of tools and the use of appropriate names, it is necessary to conduct a separate study. The same also goes for a series of ship construction,

52 M. BONINO, 1972.

53 G. FILIPI, 1997.

52 M. BONINO, 1972.

53 G. FILIPI, 1997.

uspoređi niz lokalnih izraza koje koriste graditelji tradicijskih drvenih brodova⁵⁴ s oskudicom takvih izraza u standardnom hrvatskom jeziku, dolazi se do zaključka kako je u arheološkoj literaturi brodograđevne postupke moguće uglavnom opisivati, ali ne i imenovati sve dok ne uznapreduje rad na hrvatskoj pomorskoj terminologiji.

I na kraju, potrebno je iznaći odgovarajuće rješenje za razlikovanje engleskih termina *ship* and *boat*, te odgovarajućih termina u ostalim svjetskim jezicima, s kojima se susrećemo u slučaju svakoga odgovarajućeg arheološkog nalaza. Razgraničenje među terminima ne može se tretirati kao oštar rez koji jasno odvaja dvije skupine. Uvriježeno je tumačenje kako se u slučaju drvenog broda termin *boat* (tal. *barca*, fr. *bateau*) odnosi na otvoreno plovilo manjih dimenzija, dok se terminom *ship* (tal. *nave*, fr. *navire*) označava brod pokriven palubom, često opremljen s više jarbola. Steffy predlaže modificiranu definiciju po kojoj se *boat* odnosi na plovilo manjih dimenzija dizajnirano za korištenje u zaklonjenim morskim prostorima, dok *ship* označuje plovilo većih dimenzija dizajnirano za plovidbu otvorenim morem. Dimenzije, međutim, kaže Steffy, nisu uvijek presudne, jer i manji (npr. istraživački) brodovi mogu biti dizajnirani za plovidbu otvorenim morem, pa im u tome slučaju bolje pristaje termin *ship*.⁵⁵

Termin *brod*, etimološki povezan s gazom, tj. plitkim prijelazom preko vode ili općenito s mjestom gdje se prelazi vodena površina,⁵⁶ u standardnom hrvatskom jeziku označava svako plovilo osposobljeno za sigurnu i učinkovitu plovidbu.⁵⁷ Postoje i potvrde korištenja imenice u ženskom rodu,⁵⁸ što bi više odgovaralo tradicionalnoj predodžbi o brodu kao o ženskom biću o kojemu ovisi život i opstanak. *Pomorski zakonik* (NN 181/04) razlikuje termine *plovni objekt*, *brodica* i *brod*, definirajući plovni objekt kao pomorski objekt namijenjen plovidbi morem. *Brod* u tom slučaju znači pomorski objekt „čija je duljina veća od 12 m, a bruto tonaža veća od 15, ili je ovlašten prevoziti

repair and maintenance processes with whose terminology we are insufficiently familiar. If we compare the wealth of local expressions used by traditional wooden shipbuilders⁵⁴ with the scarcity of such terms in standard Croatian, we come to the conclusion that in archaeological literature it has generally been possible to describe shipbuilding processes but not to name them, as the study of Croatian maritime terminology has not yet reached a sufficiently developed level.

It is also necessary to find a suitable solution for distinguishing between the English terms *ship* and *boat*, and their corresponding terms in other global languages which we encounter in relation to archaeological finds. A distinction between the terms cannot be treated as a clear-cut separation into two categories. The widespread interpretation is that in the case of wooden ships, the term *boat* (It. *barca*, Fr. *bateau*) refers to an open vessel of smaller dimensions, while the term *ship* (It. *nave*, Fr. *navire*) denotes a vessel covered by a deck, which is often equipped with several masts. Steffy proposes a modified definition according to which the term *boat* refers to a vessel of smaller size, designed for use in sheltered maritime areas, while a *ship* denotes a vessel of larger dimensions, designed for sailing on the open sea. However, according to Steffy, size is not always decisive. For example, smaller vessels used for exploration can be designed to sail in the open sea, and therefore the term *ship* would be more appropriate for them.⁵⁵

The Croatian term *brod* is etymologically derived from the Old Slavic *brodъ*, meaning a ford, i.e. a passage across shallow water or any spot in general for crossing a body of water.⁵⁶ In standard Croatian, it denotes any vessel capable of safe and efficient sailing.⁵⁷ There is also evidence of the use of the noun *brod*, which in modern Croatian is masculine in gender, as a feminine form,⁵⁸ which better corresponds to the traditional idea of a ship being female, and upon which life and survival depend. The Maritime Act (Official Gazette of the Republic of Croatia NN 181/04) differentiates between the terms *plovni objekt* (“watercraft”), *brodica* (“boat”) and *brod*

54 Usp. npr. *imbrlati* (iskriviti platicu paljenjem); *inkunjati* (učvrstiti drvenim klinovima); *paričati* (pripremiti platicu za krivljenje); *podbačati* (dotjerati rebra teslom da oplata bolje legne); *skomčati* (orebriti brod); *skorsurati* (upustiti čavao, tj. zabiti ga tako da mu glava uđe u drvo); *stanjati* (učiniti brod vodonepropusnim) i dr.: G. FILIPI, 1997.

55 R. J. STEFFY, 2006 (1994), 7.

56 P. SKOK, 1971, 216.

57 A. I. SIMOVIĆ, 1990, 96.

58 Npr. u Šibeniku (P. SKOK, 1971, 216) ili u Šepurinama (R. VIDOVIĆ, 1984, 71).

54 See for example, *imbrlati* (to bend a plank by burning); *inkunjati* (to fasten with wooden pins); *paričati* (to prepare a plank for bending); *podbačati* (to finish the frames with an adze to fix the planking better); *skomčati* (to frame a ship); *skorsurati* (to drive in a nail so that its head enters the wood); *stanjati* (to make a ship watertight) etc.: G. FILIPI, 1997.

55 R. J. STEFFY, 2006 (1994), 7.

56 P. SKOK, 1971, 216.

57 A. I. SIMOVIĆ, 1990, 96.

58 For example, in Šibenik (P. SKOK, 1971, 216) or in Šepurine (R. VIDOVIĆ, 1984, 71).

više od 12 putnika“, a brodica pomorski objekt dužine između 2,5 i 12 m.

Sumirajući gore navedeno, dolazi se do zaključka kako je u najširem smislu opravdana uporaba termina *brod*, *plovilo* ili *plovni objekt*, ali bi u slučaju pojedinih arheoloških nalaza valjalo, uz pomoć odgovarajućeg termina, naglasiti o kakvom je nalazu ustvari riječ. Terminološka razlika predložena u *Pomorskom zakoniku* čini se prikladna i u slučaju arheoloških nalaza, ali uz primjenu definicije koju je predložio Steffy. Shodno tome, za prijevod engleskog termina *boat* može se iskoristiti termin *brodica*, ali i konvencionalni termin *barka*, talijanskoga podrijetla, također se može iskoristiti u tome smislu.

4. ZAKLJUČAK

Raspravljajući terminološke problematike posebno je važno u slučaju kompleksnog nalaza poput drvenog broda, kod kojega o čitavom nizu pravilno dokumentiranih pojedinosti ovisi konačna interpretacija i mogućnost usporedbe s drugim odgovarajućim nalazima. Odabir odgovarajućih termina ne rješava *a priori* i problem međusobnog razumijevanja, koje je moguće postići samo ako se termini intenzivno primjenjuju u specijalističkoj literaturi, a stručni tekstovi opremaju odgovarajućim terminološkim rječnicima.

Pokušaj stvaranja osnovnog pojmovnika rezultat je sve intenzivnijih istraživanja ostataka drvenih brodova u hrvatskom podmorju, koja nužno dovode do potrebe izvještavanja i objave rezultata na hrvatskom jeziku. Studenti nekoliko generacija, koji su prošli teorijsku i praktičnu obuku, bez poteškoća su usvojili radnu terminologiju broda na hrvatskom i engleskom jeziku, potrebnu za komunikaciju unutar međunarodne istraživačke ekipe. Ta činjenica najbolja je potvrda kako je u pitanju samo dosljedna primjena odabranih termina kojih je značenje jasno i nedvosmisleno definirano. Iako stvoren na osnovi relevantne brodograđevne literature, predloženi pojmovnik ne može se smatrati konačnim rješenjem problema, već tek poticajem za razmišljanje i nastavak rada na normiranju terminologije potrebne za istraživanje brodova, brodogradnje i plovidbe prošlih vremena.

Zahvaljujući financijskoj podršci Hrvatske zaklade za znanost proučavanje tehnološkog razvoja brodogradnje i plovidbe na Jadranu odvija se u okviru projekta IP-2014-09-8211 (AdriaS – Archae-

“ship”), defining a watercraft as a sea vessel intended for sea navigation. A *ship* in this case denotes a maritime vessel “whose length exceeds 12 metres, and whose gross tonnage exceeds 15 tons, or which is authorised to transport more than 12 passengers”, while a *boat* is a sea vessel between 2.5 and 12 metres in length.

The facts described above suggest that in the broad sense the interchangeable use of the terms *ship*, *vessel* or *watercraft* is justified, but sometimes in the case of individual archaeological finds, an appropriate term is needed to describe the find. The terminological distinction proposed in the *Maritime Act* also seems appropriate for archaeological finds, together with the application of the definition proposed by Steffy. Accordingly, the Croatian term *brodica* can be used as the translation of the English term *boat*, but the conventional term *barka*, of the Italian origin, can be also used for that reason.

4. CONCLUSION

Discussing terminology is particularly important in the case of complex finds, such as wooden ships, in which the final interpretation and the possibility of making comparisons with other finds obviously depends upon a series of accurately documented details. The selection of corresponding terms does not *a priori* solve the problem of mutual understanding, which can be achieved only through intensive use of the terms in specialised literature, and by producing professional papers with relevant glossaries.

This attempt in compiling a basic terminology is the result of intensive recent excavations of wooden ship remains in Croatian waters, which has necessarily involved the need to report and publish the results in Croatian. Several generations of students with theoretical and practical training have learnt the necessary working nautical terminology, to be able to communicate in the international excavation teams. This fact best confirms that it is only a question of using selected terms whose meaning has been clearly and unambiguously defined. Although it has been compiled based on relevant shipbuilding literature, the proposed glossary cannot be considered a final solution to the problem, but rather an impulse for further reflection and a continuation of work on standardising the terminology necessary for the study of ships, shipbuilding and seafaring in the past.

Thanks to the financial support of the Croatian Science Foundation, the study of the technological

ology of Adriatic Shipbuilding and Seafaring / Arheologija jadranske plovidbe i brodogradnje), kojem je cilj uspostaviti znanstvenu disciplinu arheologije broda u okviru hrvatske arheološke znanosti, sukladno suvremenim metodološkim načelima. Taj je posao prije više od pola stoljeća započeo Zdenko Brusić, čijoj uspomeni, s divljenjem i poštovanjem, posvećujem ovaj rad.

development of naval architecture and navigation in the Adriatic has continued as part of the project IP-2014-09-8211 (AdriaS – Archaeology of Adriatic Shipbuilding and Seafaring), whose objective is to establish the scientific discipline of nautical archaeology as a part of Croatian archaeology in line with modern methodological principles. Zdenko Brusić, to whose memory I dedicate this paper with devotion and respect, started this task more than half a century ago.

Translation: Nina Matetić Pelikan (Etnotrend d. o. o.)

Proof-reading: Stephen Hindlaugh

LITERATURA / REFERENCES

- ANIĆ, V., 2004. – Vladimir Anić, *Veliki rječnik hrvatskoga jezika*, Zagreb.
- BASS, G. F., 2011. – George F. Bass, The Development of Maritime Archaeology, u/in: *The Oxford Handbook of Maritime Archaeology* (ur./eds.: A. Catsambis, B. Ford, D. L. Hamilton), Oxford, 5-22.
- BELAMARIĆ, I., 2002. – Igor Belamarić, *Alma Mater*, Split.
- BELAMARIĆ, I., 2005. – Igor Belamarić, Poznavanje broda, Zagreb.
- BELAMARIĆ, I., 2006. – Igor Belamarić, O projektiranju i konstrukciji broda, Split.
- BELTRAME, C., GADDI, A., 2000. – Carlo Beltrame, Dario Gaddi, *Iulia Felix. Documentazione e analisi degli elementi strutturali dello scafo della nave romana di Grado (GO)*, *Archeologia delle Acque*, 4, 99-102.
- BERNARDI, T., 1964. – Teodor Bernardi, *Konstrukcija drvenih brodova*, Zagreb.
- BOETTO, G., 2005. – Giulia Boetto, Le navi romane di Napoli, u/in: Daniela Giampaola *et alii*, La scoperta del porto di Neapolis: dalla ricostruzione topografica allo scavo e al recupero dei relitti, *Archeologia Maritima Mediterranea*, 2, 63-76.
- BOETTO, G., CARSANA, V., GIANPAOLA, D., 2010. – Giulia Boetto, Vittoria Carsana, Danie Gianpaola, I relitti di Napoli e il loro contesto portuale, u/in: *NAVIS: Archeologia, storia, etnologia navale, Atti del 1 convegno nazionale* (ur./eds.: S. Medas, M. D'Agostino, G. Caniato), Bari, 115-122.
- BOETTO, G., ROUSSE, C., 2012. – Giulia Boetto, Corinne Rousse, Traditions régionales d'architecture navale en adriatique à l'époque romaine, *Histria antiqua*, 21, Pula, 427-441.
- BONINO, M., 1972. – Marco Bonino, Una barca costruita da faber navalis P. Longidieno nel 1 sec. d. C., *Felix Ravenna*, 3-4, Ravenna, 19-54.
- BONINO, M., 2005. – Marco Bonino, *Argomenti di architettura navale antica*, San Giuliano Terme (Pisa).
- BORUCINSKY, M., TOMINAC COSLOVICH, S., PRITCHARD, B., 2015. – Mirjana Borucinsky, Sandra Tominac Coslovich, Boris Pritchard, Od leksikografije do terminografije u hrvatskom pomorskom nazivlju, u/in: *Od Šuleka do Schengena; Terminološki, terminografski i prijevodni aspekti jezika struke* (ur./eds.: M. Bratanić, I. Brač, B. Pritchard), Zagreb, 77-99.
- BRODSKA NOMENKLATURA, 1951. – *Brodaska nomenklatura* (sastavio Jugoslavenski registar brodova), Rijeka.
- BRUSIĆ, Z., 1968. – Zdenko Brusić, Istraživanje antičke luke kod Nina, *Diadora*, 4, Zadar, 203-210.
- BRUSIĆ, Z., 1969. – Zdenko Brusić, Podmorska arheološka istraživanja starohrvatskih brodova na ulazu u ninsku luku, *Radovi Instituta JAZU u Zadru*, 16-17, Zadar, 443-448.
- BRUSIĆ, Z., 1978. – Zdenko Brusić, Rezultati najnovijih istraživanja i vađenje starohrvatskih brodova na ulazu u ninsku luku. *Adriatica Maritima*, 2, Zadar, 5-14.
- BRUSIĆ, Z., DOMIJAN, M., 1985. – Zdenko Brusić, Miljenko Domijan, Liburnian Boats – Their Construction and Form, u/in: *Sewn Plank Boats; Archaeological and Ethnographic papers based on those presented to a conference at Greenwich in November 1984* (ur./eds.: S. McGrail, E. Kentley), BAR International Series 276, Oxford, 67-86.
- DELL'AMICO, P., 2002. – Piero Dell'Amico, *Costruzione navale antica*, Albenga.
- DELIBAŠIĆ, T., 2001. – Tatjana Delibašić, Hrvatsko pomorsko nazivlje u enciklopedijskim, leksikografskim i drugim izdanjima, *Radovi Leksikografskoga zavoda Miroslav Krleža. Razdio za leksikografiju, enciklopediku i informatiku*, 10, Zagreb, 179-187.
- FILIPPI, G., 1997. – Goran Filipi, *Betinska brodogradnja; Etimologijski rječnik pučkog nazivlja*, Šibenik.
- GARRY, J.-F., PHILIPPE, J.-P., 2009. – Jean-François Garry, Jean-Pierre Philippe, *Le guide de la construction en bois*, Paris.
- HEGEL, J. W. F., 1966. – Johan Wolfgang Wilhelm Hegel, *Filozofija povijesti*, Zagreb.

- HER 2004. – *Hrvatski enciklopedijski rječnik*, Zagreb.
- HOCKER, F. M., 1991. – Frederic M. Hocker, *The development of a bottom-based shipbuilding tradition in Northwestern Europe and the New World*, doktorski rad/PhD Thesis, College Station.
- JAL, A., 1840. – Augustin Jal, *Archéologie navale*, Paris.
- JOJIĆ, L.J., 2015. – Ljiljana Jojić (ur./ed.), *Veliki rječnik standardnoga hrvatskog jezika*, Zagreb.
- JURIĆ, R., OGUIĆ, S., VILHAR, B., 1994. – Radomir Jurić, Stošija Oguić, Božidar Vilhar, Konzervacija i početak rekonstrukcije ranohrvatskih brodova iz Nina, *Adrias – Zbornik Zavoda za znanstveni i umjetnički rad HAZU u Splitu*, 4-5, Split, 43-62.
- KARAVANIĆ, I., 2015. – Ivor Karavanić (ur./ed.), *Pojmovnik kamenoga doba*, Zagreb.
- KEBER, L., 2013. – Luciano Keber, *Tradicionalne brodice hrvatskoga Jadrana*, 2. izdanje / *Traditional Boats of the Croatian Adriatic*, 2nd edition, Zagreb.
- LAYTON, C. W. T., 1973. – Cyril Walter Thomas Layton, *Dictionary of nautical words and terms* (first edition 1955), Glasgow.
- LUCE, S. B., 1891. – Stephen B. Luce, *Text-book of seamanship. The equipping and handling of vessels under sail or steam. For the use of the United States Naval Academy*, New York.
- MARDEŠIĆ, P., 1944. – Petar Mardešić, *Pomorstvo I. dio – Brod*, Zagreb.
- MARKOVINA, R., UKALOVIĆ, T., 2010. – Roko Markovina, Tonči Ukalović, Tradicionalna tehnologija gradnje korčulanske barke – brodice (ribarice-gajete), u/in: *Zbornik radova XIX. simpozija Teorija i praksa brodogradnje in memoriam prof. Leopold Sorta (7.-9. listopada 2010., Split – Lumbarda – Korčula)* (ur./ed.: R. Markovina), Split, 105-127.
- MILOŠEVIĆ, M., MILOŠEVIĆ, Š., 1975. – Milivoj Š. Milošević, Špiro M. Milošević, *Pomorstvo 1 – udžbenik za pomorske škole*, Zagreb.
- MONDFELD, W. Z., 1979. – Wolfram Zu Mondfeld, *Encyclopédie navale des modèles réduits*, Paris.
- MUCKELROY, K., 1978. – Keith Muckelroy, *Archaeology Underwater: An Atlas of the World's Submerged Sites*, New York – London.
- POMEY, P., RIETH, E., 2005. – Patrice Pomey, Eric Rieth, *L'archéologie navale*, Collection "Archéologiques", Paris.
- POMEY, P., TCHERNIA, A., 1997. – Patrice Pomey, *La navigation dans l'antiquité*, Aix-en-Provence.
- POMEY, P., KAHANOV, Y., RIETH, E., 2012. – Patrice Pomey, Yaakov Kahanov, Eric Rieth, Transition from Shell to Skeleton in Ancient Mediterranean Ship-Construction: analysis, problems, and future research, *International Journal of Nautical Archaeology*, 41.2, 235-314.
- PRITCHARD, B., 1993. – Boris Pritchard, Povijesni razvitak hrvatske jezične leksikografije u pomorstvu, *Pomorski zbornik*, 31, Rijeka, 471-489.
- PRITCHARD, B., 1997. – Boris Pritchard, O ranom razdoblju hrvatske jezične leksikografije u pomorstvu, *Riječ*, 1, Rijeka, 57-65.
- RADIĆ ROSSI, I., 2012. – Irena Radić Rossi, Podvodna/podmorska arheologija, arheologija pomorstva i arheologija broda: razmatranje terminoloških pitanja / Underwater/Submarine, Maritime and Nautical Archaeology: Discussing Some Terminological Issues), *Archaeologia Adriatica*, 6.1, Zadar, 207-230.
- RADIĆ ROSSI, I. *et al.*, 2013. – Irena Radić Rossi, Mauro Bondioli, Mariangela Nicolardi, Zdenko Brusić, Lovorka Čoralčić, Filipe Vieira de Castro, Brodolom kod Gnalica – Ogledalo renesansne Europe / The Shipwreck of Gnalica – Mirror of Renaissance Europe), u/in: *Brodolom kod Gnalica Gnalčić; Blago potonulog broda iz 16. stoljeća, katalog izložbe / Gnalčić; Treasure of a 16th century sunken ship, exhibition catalog*) (ur./eds.: A. Filep, E. Jurdana, A. Pandžić), Zagreb, 65-95.
- RADIĆ ROSSI, I., BRUSIĆ, Z., 2014. – Irena Radić Rossi, Zdenko Brusić, Tisućljetno pomorstvo Nina na razmeđu Liburnije i Dalmacije, u/in: *Dalmacija u prostoru i vremenu – Što Dalmacija jest, a što nije?*, *Zbornik radova sa Znanstvenog skupa, Sveučilište u Zadru*, 14. – 16. lipnja 2012. (ur./eds.: L. Mirošević, V. Graovac Matassi), Zadar, 21-33.
- RIVAL, M., 1991. – Michel Rival, *La charpenterie navale romaine. Travaux du Centre Camille Jullian 4*, Centre national de la recherche scientifique, Paris.
- SIMOVIĆ, A. I., 1990. – Anton I. Simović (ur./ed.), *Pomorski leksikon*, Zagreb.
- SKOK, P., 1971. – Petar Skok, *Etimologijski rječnik hrvatskoga ili srpskoga jezika 1-4*, Zagreb.
- SKRAČIĆ, V., 2003. – Vladimir Skračić, Kurnaska gajeta – sveti brod, *Čakavska rič*, 31.1-2, Split, 33-51.
- STEFFY, R. J., 2006 (1994). – Richard J. Steffy, *Wooden Shipwrecks and the Interpretation of Shipwrecks*, College Station.
- STEPANIĆ, Ž., 2004. – Željko Stepanić, *U potrazi za (izgubljenim) hrvatskim pomorskim nazivljem: kako je žabar na brodu otkrio žabu zjevaču u 24 i 1/24 dana*, Split.
- STEPANIĆ, Ž., 2011. – Željko Stepanić, *Povijest stvaranja hrvatskoga pomorskog nazivlja u 19. i 20. stoljeću*, doktorski rad/PhD Thesis, Zadar.
- STOLAC, D., 1998. – Dijana Stolac, *Hrvatsko pomorsko nazivlje*, Rijeka.
- ŠONJE, J. 2000. – Jure Šonje (ur./ed.), *Rječnik hrvatskoga jezika*, Zagreb.
- TEŽAK-GREGL, T., 2015. – Tihomila Težak-Gregl, Dosadašnji rad na arheološkom strukovnom nazivlju, u/in: *Pojmovnik kamenoga doba* (ur./ed.: I. Karavanić), Zagreb, 13-20.
- VAN GAASBEEK, R. M., 1918. – Richard M. Van Gaasbeek, *A Practical Course in Wooden Boat and Ship Building*, Chicago.
- VIDOVIĆ, R., 1982. – Radovan Vidović, Povijest rada na sakupljanju i obradi naše pomorske terminologije (od početka do Drugoga svjetskog rata), *Mogućnosti*, 8-10, Split, 770-803.
- VIDOVIĆ, R., 1984. – Radovan Vidović, *Pomorski rječnik*, Split.
- VRŠALOVIĆ, D., 1974. – Dasen Vrsalović, *Istraživanje i zaštita podmorskih arheoloških spomenika u SR Hrvatskoj*, Zagreb.

PRIJEDLOG OSNOVNOG POJMOVNIKA ZA POTREBE ARHEOLOGIJE BRODA⁵⁹
 PROPOSAL OF BASIC GLOSSARY OF TERMS USED IN NAUTICAL ARCHAEOLOGY

Oznaka Mark	HRVATSKI NAZIV CROATIAN TERM	OBJAŠNJENJE I NARODNI NAZIV(I) EXPLANATION AND LOCAL TERM(S)	ENGLJSKI NAZIV ENGLISH TERM
1 – OPĆI POJMOVI / GENERAL TERMS			
1.1	osnivanje broda	početak i postupak stvaranja projekta novog broda do stadija njegove minimalne ali dovoljne definiranosti <i>beginning and process of designing a new ship until it has been minimally but sufficiently defined</i>	<i>ship design</i>
1.2	brodogradnja	djelatnost i znanost koja se bavi osnivanjem i izgradnjom broda <i>science or profession of designing and building boats and ships</i>	<i>shipbuilding</i>
1.3	brod, brodica, barka	plovno sredstvo koritastog oblika za prijevoz ljudi i robe <i>a trough-shaped vessel used for transporting people and goods</i>	<i>ship, boat</i>
1.4	trup, korito	sveukupnost uzdužnih i poprečnih građevnih elemenata koji čine brod <i>totality of all longitudinal and transverse construction elements that make up a ship</i>	<i>hull</i>
1.5	ljuska	vanjska oplata broda <i>external planking of the vessel</i>	<i>shell</i>
1.6	pramac	prednji dio broda (<u>prova</u>) <i>fore part of the ship (prova)</i>	<i>bow</i>
1.7	krma	stražnji dio broda <i>aft part of the ship</i>	<i>stern</i>
1.8	bok	strana broda (<u>banda</u>) <i>side of a ship (banda)</i>	<i>side</i>
1.9	desni bok, (desna strana broda)	desna strana broda, gledano od krme prema pramcu, <i>right side of the ship, looking from stern towards bow</i>	<i>starboard</i>
1.10	lijevi bok, (lijeva strana broda)	lijeva strana broda, gledano od krme prema pramcu <i>left side of the ship, looking from stern towards bow</i>	<i>port (portside)</i>
1.11	kostur	kobilica sa statvama i rebrima (<u>korban</u>) <i>keel with posts and frames (korban)</i>	<i>skeleton</i>
1.12	orebrenje	sustav brodskih rebara (<u>buškamenat</u>) <i>system of frames (buškamenat)</i>	<i>framing</i>
1.13	oplata	sveukupnost platica <i>totality of outer planks</i>	<i>planking</i>
1.14	paluba	gornji zatvoreni dio trupa (<u>kuverta</u>) <i>the closed upper part of the hull (kuverta)</i>	<i>deck</i>
1.15	potpalublje	unutrašnjost broda namijenjena teretu ili putnicima (<u>štiva</u>) <i>lower interior part of a ship for cargo or passengers (štiva)</i>	<i>hold</i>
1.16	ukrepa	element koji ukrepljuje (učvršćuje, pojačava, ukrućuje) brodsku konstrukciju <i>reinforcing (stiffening) element of the ship's construction</i>	<i>stiffener</i>
1.17	nadvođe	dio broda koji ne uranja u more <i>part of the hull which is not immersed in the sea</i>	<i>topside</i>

59 Podcrtani narodni nazivi uvršteni su u *Veliki rječnik standardnoga hrvatskog jezika*, tiskan 2015. (LJ. JOJIĆ, 2015). Nazivi koji su uvršteni u Rječnik, ali im nije pripisano značenje navedeno u tablici ostali su nepodcrtani.

The underlined common terms are listed in Veliki rječnik standardnoga hrvatskog jezika (The Great Dictionary of Standard Croatian), printed in 2015 (LJ. JOJIĆ, 2015). The terms listed in the Dictionary, but had not been assigned a special meaning are not underlined.

1.18	podvođe, ribina	dio trupa broda uronjen u more (<i>živa banda</i>) <i>part of the hull immersed in the sea (živa banda)</i>	<i>underwater parts, quick works</i>
1.19	dno	donji dio trupa broda, ispod uzvoja <i>lower part of the hull below the bilge</i>	<i>bottom</i>
1.20	uzvoj	zakrivljeni prijelaz iz dna u bok broda <i>parts of the hull where the vertical sides curve inwards to form the bottom</i>	<i>bilge</i>
1.21	vodna linija	plovna ravnina do koje uroni brod u vodu/more - potpuno opremljen natovaren i potpuno opremljen bez tereta <i>intersection of the floating plan with the external surface of the bottom of a ship – fully fitted loaded, and fully fitted unloaded</i>	<i>water line</i>
1.21	nosivost	težina tereta pod utjecajem kojega uroni brod od lake na teretnu vodenu liniju - uključuje i pitku vodu, potrošni materijal za potrebe broda, posadu i njen inventar <i>weight of cargo plus potable water, consumable stores, passengers and inventory that causes a ship to immerse from light to load waterline</i>	<i>deadweight</i>
1.22	gaz	mjera za dubinu, do koje je brod uronjen u vodu; mjeri se od vodne linije do najnižeg dijela broda <i>unit of measurement for the depth to which a ship is immersed in the water, as measured from the waterline to the lowest part of the ship</i>	<i>draught, draft</i>
1.23	istisnina, deplasman	masa vode/mora koju brod istisne svojim uronjenim dijelom <i>weight of the volume of water displaced by the immersed part of a ship</i>	<i>displacement</i>
2 – UZDUŽNI GRAĐEVNI ELEMENTI TRUPA / LONGITUDINAL ELEMENTS OF THE HULL			
2.1	kobilica	osnovna greda na dnu broda na koju se pričvršćuju rebra i statve (<i>kolumba</i>) <i>lengthwise timber structure along the base of a ship supporting the framework of the whole (kolumba)</i>	<i>keel</i>
2.2	kobilični utor	dosjed za dokobiličnu platicu na bočnoj strani kobilice; na utoru se razlikuje srednji, unutarnji i vanjski brid <i>long groove cut into the edge of the keel to receive the garboard strake; with the middle, inside and outside edge of the groove</i>	<i>rabbet</i>
2.3	rebreni utor	utor na gornjoj strani kobilice koji služi da se u nju upusti rebro; ponekad se dijelom nalazi i na rebro <i>groove on the upper side of the keel to receive a frame; sometimes partly positioned on the frame</i>	<i>recess, cut</i>
2.4	protukobilica	greda koja se dodaje na kobilicu s donje strane, u slučaju kad dužina i/ili čvrstoća kobilice nisu zadovoljavajuće <i>timber fastened to the bottom of the main keel to increase its length and/or strength, in the case that the length of the strength of the keel are not satisfactory</i>	<i>rider keel</i>
2.5	središnji (kobilični) umetak	element koji se dodaje na kobilicu s gornje strane, između protustatvi ili pramčanih i krmenih umetaka, a ispod rebrenica, kako bi ih podigla na pravu visinu i međusobno učvrstila <i>timber fastened to the top of the keel, between the posts or the deadwoods, and under the floor timbers, to give them the proper rising, and to better secure them to each other</i>	<i>rising wood</i>
2.6	štitna kobilica	daska koja štiti donji dio kobilice (<i>šuraoš, šjoleta</i>) <i>plank attached to the bottom of the keel to protect its lower surface (šuraoš, šjoleta)</i>	<i>false keel, keel shoe, shole</i>
2.7	plosna kobilica	ravna kobilica, daska deblja od platica koja zamjenjuje kobilicu <i>a thick plank used in lieu of a keel</i>	<i>flat keel, keel plank, center plank</i>
2.8	pramčana statva	nastavak kobilice u pramčanom dijelu broda (<i>ašta o' prove</i>) <i>continuation of the keel at the bow of a shi (ašta o' prove)</i>	<i>stem</i>
2.9	peta pramčane statve	element koji veže pramčanu statvu i kobilicu <i>element connecting the stem and keel</i>	<i>forefoot, gripe</i>

2.10	krmena statva	nastavak kobilice u krmenom dijelu broda (<i>ašta o' krme</i>) <i>continuation of the keel at the stern of a ship (ašta o' krme)</i>	<i>sternpost</i>
2.11	peta krmene statve	element koji veže krmenu statvu i kobilicu (<i>kalkanj</i>) <i>element connecting the sternpost and keel (kalkanj)</i>	<i>stern knee</i>
2.12	statveni utor	nastavak kobiličnog utora na pramčanoj ili krmenoj statvi <i>continuation of rabbet on stems or sternposts</i>	<i>stem/sternpost rabbet</i>
2.13	pramčana protustatva, uklada	element koji s unutrašnje strane prati pramčanu statvu (<i>kontraašta, ancikor</i>) <i>element wich from the inner side follows the stem (kontraašta, ancikor)</i>	<i>apron</i>
2.14	pramčana protupeta	prijelazni element pramčane protustatve (<i>karoc o' prove</i>) <i>curved transitional part of the apron (karoc o' prove)</i>	<i>apron</i>
2.15	pramčano uzvojno koljeno	element s unutrašnje strane pramčane protupete i protustatve, obično se nastavlja na hrptenicu <i>element attached to the inner side of the apron, which is usually a continuation of the keelson</i>	<i>stemson</i>
2.16	krmena protustatva	element koji se s unutrašnje strane nastavlja na hrptenicu ili krmeno uzvojno koljeno, i prati statvu (<i>kontraašta</i>) <i>element attached to the inside of the keelson or the sternpost knee, and following the post (kontraašta)</i>	<i>inner post</i>
2.17	krmeno uzvojno koljeno	prijelazni element na koji se nastavlja krmena protustatva (<i>karoc o' krme</i>) <i>a transition element to which the inner post is attached (karoc o' krme)</i>	<i>sternpost knee</i>
2.18	umetak, umetak mrtvog ugla, mrtva statva	drveni element koji se dodaje nad kobilicu u pramčanom ili krmenom dijelu broda, kako bi se ispunili uski dijelovi brodskog trupa <i>wooden element added to the top of the keel at the bow or stern of a ship in order to fill the narrow parts of a ship's hull</i>	<i>deadwood</i>
2.19	krmeno zrcalo	poprečna ploha kojom završava nadvodni dio oplata krme <i>transversal surface ending of the stern planking above the waterline</i>	<i>stern transom</i>
2.20	hrptenica, hrbtenica, središnje pasmo	jača drvena greda, najčešće pravokutnog presjeka, koja s unutrašnje strane slijedi kobilicu (<i>parmezal, promezal, primezal</i>) <i>strong wooden beam, most frequently with a rectangular cross-section, mounted on the inside along the centreline of the keel (parmezal, promezal, primezal)</i>	<i>keelson</i>
2.21	temeljnica jarbola	drveno pojačanje s utorom za nasad jarbola (<i>škaca</i>) <i>wooden block with a mortise into which a mast is placed (škaca)</i>	<i>mast step</i>
2.22	izdubak temeljnice jarbola	otvor za nasad jarbola u temeljnici jarbola <i>mortise into which the tenoned heel of a mast is placed</i>	<i>mast mortise</i>
2.23	dohrptenica, bočno dopasmo	greda s jedne i druge strane hrptenice <i>timbers placed on both sides of the keelson</i>	<i>bilge keelson / sister keelson</i>
2.24	proveza	uzdužna gredica od krme do pamca koja s unutrašnje strane povezuje rebra – proveza dna, proveza ispod uzvoja, proveza iznad uzvoja, bočna proveza <i>longitudinal member running from stern to bow, fixed to the inside surfaces of the frames – bottom stringer, below the bilge stringer, above the bilge stringer, side stringer</i>	<i>stringer, clamp</i>
2.25	palubna proveza (bočna), prvi podspanjak	uzdužna gredica od krme do pamca pričvršćena s unutrašnje strane vršnih platica; međusobno povezuje sponje i glave rebara (<i>kontracenta</i> – u slučaju kad brod nema linicu) <i>longitudinal member running from stern to bow, fastened to the inside of the top planks, interconnecting deck beams and frame heads (kontracenta – in the case when the ship has no bulwark)</i>	<i>shelf clamp</i>

3 – POPREČNI GRAĐEVNI ELEMENTI TRUPA / TRANSVERSAL ELEMENTS OF THE HULL			
3.1	rebro	u najširem značenju dio brodskog trupa postavljen poprečno na kobilicu; glavni element poprečne čvrstoće broda (<i>glava</i>) <i>in the broadest sense of the word, part of a ship's hull, set transversally to the keel; the main element of a ship's transverse stiffness (glava)</i>	<i>frame, rib</i>
3.2	širina rebra	širina gornje površine rebra, paralelne s kobilicom i platicama <i>width of the upper surface of the frame, parallel with keel and planks</i>	<i>frame/rib thickness, sided</i>
3.3	visina rebra	mjera bočne površine rebra, okomite na kobilicu i platice <i>unit of measurement for the side surface of the frame, vertical to the keel and the planks</i>	<i>frame/rib depth, moulded</i>
3.4	glavno rebro	središnje rebro koje je najvećom površinom uronjeno u vodu/ more <i>central frame whose largest surface is immersed in the water/sea</i>	<i>main frame</i>
3.5	rebrenica	rebro položeno na kobilicu, simetričnih krakova (<i>pjana, lukoča, kalata</i>) <i>frame timber that crosses the keel with symmetrical arms (pjana, lukoča, kalata)</i>	<i>floor timber</i>
3.6	rebrenica nejednakih krakova	rebro položeno na kobilicu, nesimetričnih krakova <i>frame that crosses the keel with asymmetrical arms</i>	<i>asymmetric floor, overlapping floor</i>
3.7	polurebrenica	rebro koje počinje od kobilice <i>frame which begins at or near one side of the keel</i>	<i>half frame</i>
3.8	rebreni nastavak; produžnik, priklad	bočno rebro koje se nastavlja na rebrenicu ili polurebrenicu (<i>capul, korba, kriva glava</i>) <i>side frame timber other than a floor timber or half-frame (capul, korba, kriva glava)</i>	<i>futtock</i>
3.9	slivnica, kaljužni otvor	otvor za slobodan protok vode na najnižem dijelu rebra; izljevnica, slivnica (<i>manikela, brunal</i>) <i>apertures cut into the bottom surfaces of frames to allow water to drain (manikela, brunal)</i>	<i>limber hole</i>
3.10	koso rebro	pramčano ili krmeno rebro postavljeno koso u odnosu na uzdužnu os broda, uslijed veće zakrivljenosti boka <i>fore or aft frame mounted obliquely to the keel centerline, due to the curvature of the ship's side</i>	<i>cant frame</i>
3.11	rašlje, vjenčanica	drveno koljeno koje se koristi da se međusobno jače vežu i učvrste lijevi i desni bok broda; u pramcu i krmu veće podspojake i proveze (<i>zoja</i>) <i>wooden knee used to reinforce and hold together the left and right sides of the ship; in the bow and stern, the large girders and stringers (zoja)</i>	<i>breast hook</i>
3.12	vijenac, vjenčanica	drveno koljeno dužih krakova koji su najčešće napravljeni dodavanjem dvaju nastavaka <i>wooden knee with long arms, mostly made by adding two ends</i>	<i>breast hook (composite)</i>
3.13	apostol	pramčano rebro pričvršćeno uz bočne strane statve (i protostatve), kojem je svrha povećati prislon glava platica vanjske oplata uz samu statvu i povećati čvrstoću čitavog sklopa; leži u ravni paralelnoj s uzdužnom osi broda; naziv potječe iz vremena kad ih je bilo po šest sa svake strane unutar pramčanog dijela broda <i>the aft frame fastened to the side of the post (and apron), which serves to reinforce the adherence of the heads of the outern planks to the post, and increase the strength of the whole structure; lies in the surface parallel to the longitudinal axis of the ship; the name originates from the period when there were six such peaces on each side, in the bow of the ship</i>	<i>hawse timber, knighthead</i>
3.14	pregrada	element koji dijeli prostor broda u manje dijelove <i>vertical partition which divides the hold of the ship into smaller spaces</i>	<i>buklhead</i>

3.15	spolja	poprijezni potporanj na kojemu leži paluba (<i>katina, žbaj</i>) <i>timber mounted athwartships to support the decks (katina, žbaj)</i>	<i>deck beam</i>
3.16	koljeno	okomito ili vodoravno postavljen drveni element kojim se učvršćuju spojevi između elemenata brodske konstrukcije, npr. između spolja i rebara <i>vertically or horizontally set angular piece of timber used to reinforce the junction of two surfaces of different planes (for example deck beams and frames)</i>	<i>knee</i>
3.17	upora	uspravni stup koji podupire spolju <i>upright supporting post for deck beams</i>	<i>stanchion</i>
3.18	klupa	element koji poprečno ukrepljuje brodsko korito, a koristi se za sjedenje putnika ili veslača (<i>banak</i>) <i>transverse plank in a ship's hull used to seat passengers or rowers (banak)</i>	<i>thwart</i>
4 – OPLATA TRUPA / PLANKING			
4.1	vanjska oplata	vanjsko opločenje trupa broda <i>the outer lining or shell of a ship's hull</i>	<i>outer planking</i>
4.2	platica, trenica	daska oplata (<i>madir</i>) <i>plank belonging to the planking (madir)</i>	<i>plank</i>
4.3	voj	jedan red platica, od pramčane do krmene statve (<i>fil</i>) <i>continuous line of planks, usually running from bow to stern (fil)</i>	<i>strake</i>
4.4	dokobilična platica	prva deblja platica uz koblicu (<i>picun, panižel</i>) <i>first, slightly thicker plank next to the keel (picun, panižel)</i>	<i>garboard plank</i>
4.5	razma ⁶⁰ , porub	element koji s gornje strane povezuje vrhove rebara, od pramčane do krmene statve (<i>kuvertela</i>); u slučaju kad je linica izrađena od rebrenih nastavaka, nalazi se na vrhu linice <i>timber attached to the top of the ship's frames, running from stem to sternpost (kuvertela); when the bulwark is made of futtocks (top timbers) it is positioned at the top of the bulwark</i>	<i>caprail</i>
4.6	završna platica, završni voj	Najviša platica tj. najviši voj vanjske oplata ispod razme (<i>centa, reja</i>) <i>uppermost plank / strake of outer planking below the caprail (centa, reja)</i>	<i>sheer plank, sheer strake</i>
4.7	žuljnica, bokoštinitica	deblji voj na vodnoj liniji ili više, koji služi da se s vanjske strane opaše i učvrsti brodsko korito <i>thick strake of planking located along or above the waterline for the purpose of girding and stiffening the ship's outer hull</i>	<i>wale</i>
4.8	unutarnja oplata	platice postavljene s unutrašnje strane rebara <i>planks attached to the inside of the frames</i>	<i>ceiling, inner planking</i>
5 – PALUBA I POTPALUBLJE / DECK AND HOLD			
5.1	palubna platica / trenica	daska opločenja palube <i>plank of a ship's deck</i>	<i>deck plank</i>
5.2	oplata palube	sveukupnost palubnih trenica, palubnih proveza i srznice ili razme <i>deck strakes, shelf clamps and planksheer or caprail collectively</i>	<i>deck planking</i>

60 Po pitanju definiranja termina *razma* postoje u literaturi velike razlike (kao ilustraciju velikih razlika u interpretaciji usp. npr. T. BERNARDI 1964, sl. 96; 94; M. MILOŠEVIĆ, S. MILOŠEVIĆ, 26, sl. 26; <https://www.fsb.unizg.hr/geometrija.broda/donji/glosarij.htm>). U ovom slučaju termin je odabran kao najprikladniji prijevod termina *caprail*.

The term razma is differently explained in various publications (for the illustration see T. BERNARDI 1964, sl. 96; 94; M. MILOŠEVIĆ, S. MILOŠEVIĆ, 26, sl. 26; <https://www.fsb.unizg.hr/geometrija.broda/donji/glosarij.htm>). In this case, the term was chosen as the best translation of the term caprail.

5.3	palubni otvor, grotlo	otvor na palubi kroz koji se krca teret ili ulazi u potpalublje (<i>bokaporta</i>)	<i>hatchway</i>
		<i>opening in a deck for loading cargo or entering the hold (bokaporta)</i>	
5.4	pramnica	uzdignuta paluba na pramcu broda (<i>kaštel</i>)	<i>forecastle</i>
		<i>raised forward part of a ship's upper deck (kaštel)</i>	
5.5	krmnica	uzdignuta paluba na krmi broda (<i>kasar</i>)	<i>poop deck</i>
		<i>highest and aftermost deck of a ship (kasar)</i>	
5.6	nadgrađe broda	konstrukcija nad palubom broda, koja se proteže od boka do boka broda	<i>superstructure</i>
		<i>construction above the deck, stretching from side to side of a ship</i>	
5.7	linica	nastavak boka broda iznad gornje palube izrađen od izdanaka ili rebrenih nastavaka optočenih s vanjske i unutrašnje strane lakšom oplatom (<i>partigeta, mrtva banda</i>)	<i>bulwark</i>
		<i>continuation of the side of a ship above its upper deck that is made of stanchions or joined pieces of frame, with light inner and outer planking (partigeta, mrtva banda)</i>	
5.8	izdanak	drveni stupić postavljen nad razmu, sastavni dio kostura linice (<i>štil⁶¹</i>)	<i>bulwark stanchion</i>
		<i>wooden post above the caprail, part of the bulwark skeleton (štil⁶¹)</i>	
5.9	lakomica	rupa na linici, za istjecanje vode s palube (<i>manikela</i>)	<i>scupper</i>
		<i>hole in the bulwark to drain off deck water (manikela)</i>	
5.10	bočno pasmo	gredica ili daska duž bočnih strana broda na koju se naslanja podnica (<i>verzina</i>)	<i>bilge clamp</i>
		<i>member or plank along the sides of a ship which is connected to the floor (verzina)</i>	
5.11	podnica	pomične daske koje prekrivaju donji dio unutrašnjosti broda (<i>pajolada</i>)	<i>floor</i>
		<i>removable planks which cover the lower part of the ship's hold (pajolada)</i>	
5.12	daska podnice	pomična daska u dnu broda, sastavni dio podnice (<i>pajol</i>)	<i>limber board</i>
		<i>removable planks in the lower part of a ship (pajol)</i>	
5.13	kaljužnica	prostor između podnice i dna broda (<i>santina</i>)	<i>bilge</i>
		<i>area between the flooring and the bottom of a ship (santina)</i>	
6 – DODATNI UKRASNI I FUNKCIONALNI ELEMENTI / ADDITIONAL ORNAMENTAL AND FUNCTIONAL ELEMENTS			
6.1	pulena	Izrezbarena figura na pramcu broda – obično ljudski ili životinjski lik, ili mitološko biće (<i>u slučaju životinje ili mitološkog bića: beštijun, zvir</i>)	<i>figurehead</i>
		<i>carved figure on a ship's bow, usually a human or animal figure, or a mythological creature (in the case of animals or mythological creatures: beštijun, zvir)</i>	
6.2	bojni kljun	ojačani produžetak pramca ispod vodene linije, oštrog vrha, u obliku kljuna, koji služi kao oružje za probijanje trupa neprijateljskog broda	<i>ram</i>
		<i>reinforced projection on the bow placed below the waterline, with a sharp, beak-shaped peak, used as a weapon to strike the hull of a hostile ship</i>	
6.3	valosjek	produžetak pramca ispod vodene linije, zaobljen sa oštrim bridom, koji služi u svrhu lakšeg sječenja valova	<i>cutwater</i>
		<i>forwardmost part of the stem, placed below the waterline, rounded and with a sharp edge, used to part the waves</i>	

61 Termin se odnosi i na krajnji dio rebara iznad palube, u slučaju kad oni čine kostur linice.

The term refers also to the toptimbers, forming a bulwark.

6.4	uzvojna/ljuljna/bočna kobilica	bočna kobilica; dugačka i uska gredica, paralelna s kobilicom, koja se nalazi na prijelazu dna u bok broda i služi za stabilizaciju	<i>bilge keel</i>
		<i>secondary keel; a long and narrow member parallel with the keel, placed where the vertical sides curve inwards to form the bottom of a ship to improve stability</i>	
6.5	balast	težak materijal smješten u dnu broda zbog povećanja stabilnosti (<i>saurna, sournja</i>)	<i>ballast</i>
		<i>heavy material placed low in the hold to improve stability (saurna, sournja)</i>	
7 – ELEMENTI ZA SPAJANJE, SPOJEVI I TEHNIKE / JOINING ELEMENTS, JOINTS AND TECHNIQUES			
7.1	čavao	metalni element sastavljen od glave, struka – okruglog ili četvrtastog – i šiljka (<i>čaval, brokva, brukva</i>)	<i>nail</i>
		<i>small metal spike – round or rectangular – with a broadened flat head (čaval, brokva, brukva)</i>	
7.2	svornjak	metalni element koji se sastoji od struka i glave; može biti s narezom i maticom	<i>bolt</i>
		<i>metal pin with a head; it can be threaded, with a nut</i>	
7.3	drveni čavao, čivija	drveni element kružnog ili poligonalnog presjeka, koji međusobno veže dijelove broda (<i>kavija</i>)	<i>treenail</i>
		<i>rounded or multi-sided wooden element driven through planks and timbers to connect them (kavija)</i>	
7.4	utor	otvor na bočnoj strani platice u koji ulazi jezičac, u slučaju primjene tehnike spajanja platice uz pomoć utora i jezičaca	<i>mortise</i>
		<i>cavity cut into a plank to receive a tenon (mortise-and-tenon joint)</i>	
7.5	jezičac	drvena pločica pravokutnog oblika koja se umeće u utore u platicama, kako bi ih međusobno povezala	<i>tenon</i>
		<i>rectangular wooden plate inserted into a corresponding mortises, to join two planks</i>	
7.6	zakrpnj jezičac	jezičac koji je naknadno umentnut s vanjske ili unutrašnje strane oplata, u slučaju popravka	<i>patched tenon</i>
		<i>tenon subsequently inserted from the exterior or interior surface of a plank in the replacement of rotten or damaged planking</i>	
7.7	mali drveni čavao	drveni element okruglog ili poligonalnog presjeka i izrazito malih dimenzija kojim se jezičci utaknuti u utore pričvršćuju za platice	<i>peg</i>
		<i>extraordinarily small wooden pin with a round or multi-sided cross-section used to lock a mortise-and-tenon joint</i>	
7.8	spoj na utor i jezičac	međusobno spajanje drvenih dijelova uz pomoć nasuprotnih utora u koje se ulažu tanki drveni jezičci	<i>mortise and tenon joint</i>
		<i>connecting wooden members by fitting thin wooden plates (tenons) into facing cavities (mortises)</i>	
7.9	ključ (obični, na zub, na čep i kutiju)	spoj kojim se uzdužno spajaju dva komada drva (<i>čov</i>)	<i>scarf (joint)</i>
		<i>overlapping joint used to connect two timbers or planks</i>	
7.10	lastin rep	poprečna veza između dva komada drva postignuta uklapanjem trokutasto oblikovanog izdanka na jednom u odgovarajući utor na drugo dijelu	<i>dovetail</i>
		<i>diagonal joining of two pieces of timber achieved by inserting a triangular stanchion on one side into a corresponding mortise on the other</i>	
7.11	spoj na sljub/stik	spoj izveden međusobnim sučeljavanjem elemenata (<i>tresas</i>)	<i>butt joint</i>
		<i>joining of two elements whose ends are cut perpendicularly to their lengths (tresas)</i>	
7.12	sljubnica	razmak između dviju platice kod glatke gradnje (<i>kimenat</i>)	<i>seam</i>
		<i>seam between two planks in carvel work (kimenat)</i>	

7.13	glatka/stična gradnja	tehnika gradnje vanjske oplata kojom se platice tupo sljubljuju u uzdužnom i poprečnom smjeru	<i>carvel work</i>
		<i>technique of building the outer planking by fastening the planks edge to edge in the longitudinal and transversal direction</i>	
7.14	prijeklopna gradnja	tehnika gradnje vanjske oplata kojom se platice postavljaju od kobilice, tako da svaka slijedeća gornja prekriva donju na prijeklop	<i>clinker work</i>
		<i>technique of building the outer planking by overlapping the edges of planks, starting from the keel</i>	
7.15	konstrukcija prvo ljuska	postupak gradnje broda pri kojem se prvo izrađuje vanjska oplata, a potom umeću rebra	<i>shell first construction</i>
		<i>construction process in which the outer hull planking is erected before frames are attached to it</i>	
7.16	konstrukcija prvo kostur	tehnika gradnje broda kojom se prvo izrađuje korstur (kobilica, statve i rebra), a potom postavljaju platice	<i>skeleton first construction</i>
		<i>construction process in which the hull is constructed by first erecting the skeleton (keel, posts and frames), and then attaching the planking to it</i>	
7.17	konstrukcija prvo dno	tehnika gradnje broda kojom se u u prvoj fazi izrađuje brodsko dno privremenim povezivanjem platice dna	<i>bottom-based construction</i>
		<i>shipbuilding technique in which the first stage of construction consists in temporary fastening of the bottom planks</i>	
7.18	šivanje (vezanje)	tehnika međusobnog spajanja platice i ostalih elemenata brodske konstrukcije provlačenjem veziva, najčešće konopa, kroz nizove rupica	<i>sewing, lashing</i>
		<i>technique of connecting planks and other elements of ship construction by threading a binding (most frequently a rope) through a series of holes</i>	
8 – ZAŠTITA I ODRŽAVANJE / PROTECTION AND MAINTENANCE			
8.1	šuperenje	brtvljenje šupljina i spojeva među drvenim dijelovima broda kako bi postali nepropusni (<i>kalafatanje</i>)	<i>caulking</i>
		<i>making the seams and joints watertight by compressing caulk between the planks or strakes of a wooden hull (kalafatanje)</i>	
8.2	kučina	materijal korišten za šuperenje; ostatci konoplje ili lana (<i>stupa</i>)	<i>oakum</i>
		<i>material used for caulking; the remains of hemp or flax (stupa)</i>	
8.3	smola	crna borova smola koja se koristi za zaštitu drvene brodske konstrukcije (<i>pakal, paklina, pegula</i>)	<i>pitch</i>
		<i>black pine resin used for the protection of a wooden ship structure (pakal, paklina, pegula)</i>	
8.4	obnova platice	duža daska (<i>lancola</i>) ili kraća daska (<i>tašel</i>) kojom se zamjenjuje oštećeni dio platice	<i>plank repair, plank replacement</i>
		<i>long plank (lancola) or short plank (tašel) used in lieu of a damaged part of a plank</i>	
8.5	olovna obloga	vanjska zaštita donjeg dijela korita u obliku ploča od olovnog lima	<i>lead sheeting</i>
		<i>outside protection of the bottom part of the hull in the form of lead sheet plates</i>	
8.6	olovna zakrpnna pločica	pločica olovnog lima koja se koristi za pojačanje oštećenog, istrošenog ili oslabljenog dijela brodske konstrukcije	<i>lead patch</i>
		<i>lead sheet plate attached to reinforce the damaged, used or weakened part of a ship's structure</i>	

9 – OPREMA / EQUIPMENT			
9.1	jarbol	obla drvena greda učvršćena u temeljnicu jarbola, okomita ili lagano koso nagnuta prema krmi	<i>mast</i>
		<i>a round wooden beam affixed vertically to the mast step or slightly diagonally bent towards the stern</i>	
9.2	kosnik	kosa oblica utaknuta u pramac koja služi za pripinjanje jarbola prema pramcu i za razapinjanje prečaka (<i>bumpreš</i>)	<i>bowsprit</i>
		<i>spar extending forward from the vessel's bow, used to carry the forestay as forward as possible, and to support the headsails (bumpreš)</i>	
9.3	jedro (križno, sošno, oglavno, latinsko, prečka)	skrojen i porubljen komad platna razapet na brodu i izložen vjetru koji se koristi za pokretanje broda (<i>idro</i>)	<i>sail</i> (<i>square sail, spritsail, lugsail, lateen sail, headsail</i>)
		<i>a piece of fabric sewn together and fitted to the spars and rigging of a ship so as to convert the force of the wind into the forward motion of the ship (idro)</i>	
9.4	snast (jarbolje, jedrilje, oputa i vrv)	svi elementi brodske opreme koji neposredno ili posredno služe za poriv broda vjetrom: 1. jarbolje: jarbol, kosnik i pripadajuća oprema; 2. jedrilje: jedra i pripadajuća oprema; 3. oputa: konopi za pripinjanje jarbola i kosnika, 4. vrv: konopi za pokretanje i kontrolu jedara <i>all parts of a ship's fittings directly or indirectly used to convert the force of the wind into the forward motion of the ship:</i> 1. <i>masts: mast, bowsprit and fittings;</i> 2. <i>sails: sails and fittings;</i> 3. <i>standing rigging: ropes for affixing the mast and bowsprit;</i> 4. <i>running rigging: ropes for moving and controlling the sails</i>	<i>rigging</i> (<i>masts, sails, standing rigging, running rigging</i>)
9.5	pripona	dio snasti i opute; konop koji veže vrh jarbola za bok broda radi stabilnosti (<i>sartija</i>)	<i>shroud</i>
		<i>part of the rigging; a rope fastening the top of the mast to the sides of a ship for stability (sartija)</i>	
9.6	leto (prednje i stražnje)	dio snasti i opute; konop koji veže vrh jarbola za pramac ili krmu broda	<i>stay</i> (<i>forestay, backstay</i>)
		<i>part of the rigging and standing rigging; a rope connected to the bow or stern, used to support a mast</i>	
9.7	škota	dio snasti i vrvi; konop koji se koristi za upravljanje jedrom	<i>sheet</i>
		<i>part of the running rigging; a rope used for controlling the sail</i>	
9.8	podigač	dio snasti i vrvi; konop koji služi za podizanje jedra (<i>gindac</i>)	<i>halyard</i>
		<i>part of rigging and running rigging; a rope for hoisting and lowering a sail (gindac)</i>	
9.9	krat	dio snasti i vrvi; konop koji služi za kraćenje i skupljanje jedra (<i>tercarol, trcarol</i>)	<i>brail</i>
		<i>part of rigging and running rigging; a rope a rope used for hauling the sail up or in</i>	
9.10	veslo	štap s proširenjem u donjem dijelu, namijenjen pokretanju broda	<i>oar</i>
		<i>pole with a blade at the lower end used to move a ship</i>	
9.11	nosač vesla	drveni klin na koji se natakne vjenčić kroz koji prolazi veslo (<i>škeram, škaram</i>); drveni komad na koji se naslanja veslo, u obliku ruke s ispruženim palcem (<i>palac</i>) ili nosač rašljastog oblika (<i>soha</i>)	<i>thole, tholepin, oarlock</i>
		wooden pin to which an oar lashing is attached to serve as the fulcrum for an oar (<i>škeram</i>); a wooden piece on which the oar is leaned that is in the form of a hand with a stretched thumb (<i>palac</i>) or forked mount (<i>soha</i>)	
9.12	otvor za veslo	otvor na boku broda kroz koji je provučeno veslo	<i>oar port</i>
		<i>opening in a ship's side through which the stocks of the oars are passed</i>	
9.13	jaram, igo	poprečna struktura koja prelazi bok ili oba boka broda, koja se koristi u različite svrhe, npr. veslanje	<i>outrigger</i>
		<i>structure projecting over a side, or both sides of a ship, used for various purposes, eg. rowing</i>	

9.14	vjenčić	vjenčić od konopa, volovske žile ili kože u koji se utakne veslo kod veslanja (<i>štrop</i>)	<i>oar lashing, leather strap</i>
		<i>strap made of rope, or leather into which an oar is inserted for rowing (štrop)</i>	
9.15	kormilo	element pričvršćen na krmenu statvu koji služi za održavanje ili promjenu smjera tijekom plovidbe (<i>timun</i>)	<i>rudder</i>
		<i>element attached to the sternpost to maintain or change the course of navigation (timun)</i>	
9.16	upravljачko veslo	veslo za upravljanje manjim brodom po boku ili po krmu	<i>steering oar</i>
		<i>oar used to steer a small vessel either from the side or the stern</i>	
9.17	bočno kormilo	veliko veslo pričvršćeno s bočne stražnje strane broda koje se koristilo za upravljanje prije izuma središnjeg kormila	<i>quarter rudder</i>
		<i>large oar mounted on the after side (quater) of a ship, used for steering before the invention of the central steering wheel</i>	
9.18	rudo, ručica kormila	ručka za upravljanje kormilom (<i>argutla, argola, jargutla, jargola</i>)	<i>tiller</i>
		<i>grip for operating the rudder (argutla, argola, jargutla, jargola)</i>	
9.19	šuplja glava	drveni element okruglog ili jajolikog oblika s rupama za provlačenje konopa; služi za zatezanje pripona i leta; sastavni dio stezalice (<i>bigota</i>)	<i>dead eye</i>
		<i>round or egg-shaped wooden element with holes to receive rope or wire; used to extend the shrouds and stays; the constituent part of a lanyard (bigota)</i>	
9.20	kolotur	jednostavan uređaj koji se koristi za promjenu smjera konopa; sastoji se od kućišta tj. oklopa, koluta, osovine i štropa (<i>bocel, bucel</i>)	<i>block</i>
		<i>simple device used to alter the direction of rope; consisting of a housing, a ring, an axle and a strop (bocel, bucel)</i>	
9.21	kolut	plosnata okrugla ploča sa žlijebom za konop, sastavni dio kolotura	<i>pulley, sheave</i>
		<i>flat round plate with a groove for the rope, a constituent part of a block</i>	
9.22	koloturnik	sustav kolotura koji služi za pretvorbu snage; smanjuje silu uz produženje puta	<i>block and tackle</i>
		<i>system of pulleys for lifting heavy loads by exerting little input force and increasing the mechanical advantage</i>	
9.23	bitva	drveni stupić za vezivanje konopa (<i>mankul, bita</i>)	<i>bitt</i>
		<i>wooden post used for securing ropes (mankul, bita)</i>	
9.24	kaljužna (kalna) pumpa	pumpa uz pomoć koje se izbacuje voda i kal iz kaljužnice	<i>bilge pump</i>
9.25	ispolac	naprava za izbacivanje vode iz broda (<i>paj, palj, šešula</i>)	<i>bailer</i>
		<i>device for bailing water from the ship (paj, palj, šešula)</i>	
9.26	dubinomjer, utežni	stožast predmet od olova koji se konopom spušta u more zbog mjerenja dubine (<i>škandaj</i>)	<i>sounding weight</i>
		<i>conical lead tool immersed into the sea on a rope to measure the depth (škandaj)</i>	
9.27	sidro	kameni, kameno-drveni, olovno-drveni ili željezni predmet koji se koristi za sidrenje broda (<i>ankora</i>)	<i>anchor</i>
		<i>object made of stone, stone-wood, lead-wood or iron used for anchoring a ship (ankora)</i>	

10 – ALAT / TOOLS			
10.1	blanja	alat za blanjanje tj. ravnanje drvenih površina <i>plane used to smooth rabbets</i>	<i>rabbet plane</i>
10.2	bradva	mala sjekira koja služi za tesanje dijelova koji se ne mogu dohvatiti teslom <i>axe-like tool used for shaping and dressing wooden parts that cannot be worked with a shipwright's adze</i>	<i>hatchet</i>
10.3	dlijeto	alat za obrdu drveta (lito, škarpel) <i>tool used to shape the wood (lito, škarpel)</i>	<i>chisel</i>
10.4	dlijeto za dubljenje	oštra sprava za dubljenje (<i>gujba</i>) <i>sharp gouging tool (gujba)</i>	<i>gouge</i>
10.5	kutnik	sprava u obliku trokuta ili slova L, za mjerenje i određivanje pravoga kuta (<i>škvara</i>) <i>T-shaped or L-shaped instrument for drawing or testing right angles (škvara)</i>	<i>square</i>
10.6	malj, drveni	lakši drveni čekić <i>light wooden hammer</i>	<i>mallet</i>
10.7	malj, željezni	teška sprava za udaranje (<i>maca</i>) <i>heavy device used for hammering (maca)</i>	<i>iron maul</i>
10.8	pila	alat za piljenje (<i>šega, šegac</i>) <i>tool for sawing (šega, šegac)</i>	<i>saw</i>
10.9	sjekira	alat za sječenje (<i>sikira</i>) <i>cutting tool (sikira)</i>	<i>axe</i>
10.10	stolarski šestar	dvokraka drvena ili metalna sprava za mjerenje i ocrtavanje kružnih oblika (<i>kompas</i>) <i>two-armed wooden or metal device for taking measurements and describing circles or circular arcs (kompas)</i>	<i>carpenter's compass</i>
10.11	svrdlo	alat za bušenje rupa (<i>svrdal</i>) <i>tool for boring holes (svrdal)</i>	<i>gimlet, wimble</i>
10.12	svrdlo, lučno	alat za bušenje rupa <i>tool for boring holes</i>	<i>bow drill</i>
10.13	tesla	alat za tesanje <i>tool for shaping and dressing wooden parts</i>	<i>shipwright's adze</i>

ABECEDNI POPIS POJMOVA
ALPHABETIC LIST OF TERMS

hrvatski/Croatian	engleski/English	narodni/vernacular
apostol, 3.13	anchor, 9.27	ancikor, 2.13
balast, 6.5	apron, 2.13, 2.14	ankora, 9.27
barka, 1.3	asymmetric floor, 3.6	argola/jargola, 9.18
bitva, 9.23	axe, 10.9	argutla/jargutla, 9.18
blanja, 10.1	backstay, 9.6	ašta o' krme, 2.10
bočna kobilica, 6.4	bailer, 9.25	ašta o' prove, 2.8
bočno dopasmo, 2.23	ballast, 6.5	banak, 3.18
bočno kormilo, 9.17	bilge keel, 6.4	banda, 1.8
bočno pasmo, 5.10	bilge keelson, 2.23	beštijun, 6.1
bojni kljun, 6.2	bilge pump, 9.24	bigota, 9.19
bok, 1.8	bilge clamp, 5.10	bita, 9.23
bokoštitnica, 4.7	bilge, 1.20	bokaporta, 5.3
bradva, 10.2	bilge, 5.13	brokva (brukva), 7.1
brod, 1.3	bitt, 9.23	brunal, 3.9
brodica 1.3	block and tackle, 9.22	bucel/bocel/, 9.20
brodogradnja, 1.2	block, 9.20	bumpreš, 9.2
čavao, 7.1	boat, 1.3	buškamenat, 1.12
čivija, 7.3	bolt, 7.2	capul, 3.8
daska podnice, 5.12	bottom, 1.19	centa, 4.6
deplasman, 1.23	bottom-based construction, 7.17	čov, 7.9
desni bok, 1.9	bow drill, 10.12	fil, 4.3
dlijeto za dubljenje, 10.4	bow, 1.6	frižeta, 4.5
dlijeto, 10.3	bowsprit, 9.2	gindac, 9.8
dohrptenica, 2.23	brail, 9.9	glava, 3.5
dokobilična platica, 4.4	breast hook (composite), 3.12	gujba, 10.4
drveni čavao, 7.3	breast hook, 3.11	idro, 9.3
dubinomjer, utežni, 9.26	bulkhead, 3.14	kalafatanje, 8.1
gaz, 1.22	bulwark stanchion, 5.8	kalata, 3.5
glatka gradnja, 7.13	bulwark, 5.7	kalkanj, 2.11
glavno rebro, 3.4	butt joint, 7.11	karoc o' krme, 2.17
grotlo, 5.3	cant frame, 3.10	karoc o' prove, 2.14
hrptenica/hrbtenica, 2.20	caprail, 5.9	kasar, 5.5
igo, 9.13	carpenter's compass, 10.10	kaštel, 5.4
ispolac, 9.25	carvel work, 7.13	katina, 3.15
istisnina, 1.23	caulking, 8.1	kavija, 7.3
izdanak, 5.8	ceiling, 4.8	kimenat, 7.12
izdubak temeljnice jarbola, 2.22	center plank, 2.7	kolumba, 2.1
jaram, 9.13	chisel, 10.3	kompas, 10.10
jarbol, 9.1	clamp, 2.24	kontraašta, 2.13
jarbolje, 9.4	clinker work, 7.14	kontraašta, 2.15
jedrilje, 9.4	cut, 2.3	kontracentra, 2.25
jedro, 9.3	cutwater, 6.3	korba, 3.8
jezičac, 7.5	dead eye, 9.19	korban, 1.11
kaljužna/kalna pumpa, 9.24	deadweight, 1.21	kriva glava, 3.8
kaljužni otvor, 3.9	deadwood, 2.18	kuverta, 1.14
kaljužnica, 5.13	deck beam, 3.15	kuvertela, 4.5
ključ, 7.9	deck plank, 5.1	lancola, 8.4

hrvatski/Croatian	engleski/English	narodni/vernacular
klupa, 3.18	deck planking, 3.2	lito, 10.3
kobilica, 2.1	deck, 1.14	lukoča, 3.5
kobilični utor, 2.2	dovetail, 7.10	maca, 10.7
koljeno, 3.16	draught/draft, 1.22	madir, 4.2
kolotur, 9.20	false keel, 2.6	manikela, 3.9
koloturnik, 9.22	figurehead, 6.1	manikela, 5.9
kolut, 9.21	flat keel, 2.7	mankul, 9.23
konstrukcija prvo dno, 7.17	floor timber, 3.5	pajol, 5.12
konstrukcija prvo kostur, 7.16	floor, 5.11	pajolada, 5.11
konstrukcija prvo ljuska, 7.15	forecastle, 5.4	pakal, 8.3
korito, 1.4	forefoot, 2.9	paklina, 8.3
kormilo, 9.15	forestay, 9.6	palac, 9.11
kosnik, 9.2	frame, 3.1	palj (paj), 9.25
koso rebro, 3.10	frame/rib depth, 3.3	panižel, 4.4
kostur, 1.11	frame/rib thickness, 3.2	paramezal/promezal/primezal 2.20
krat, 9.9	framing, 1.12	partigeta, 5.7
križno jedro, 9.3	futtock, 3.8	pegula, 8.3
krma, 1.7	garboard plank, 4.4	picun, 4.4
krmena protustatva, 2.16	gimlet, 10.11	pjana, 3.5
krmena statva, 2.10	gouge, 10.4	prova, 1.6
krmeno uzvojno koljeno, 2.17	gripe, 2.9	reja, 4.6
krmeno zrcalo, 2.19	gunwale, 4.5	santina, 5.13
krmnica, 5.5	gunwale, 5.9	sartija, 9.5
kučina, 8.2	half frame, 3.7	saurna, 6.5
kutnik, 10.5	halyard, 9.8	šega/šegac, 10.8
lakomica, 5.9	hatchet, 10.2	šešula, 9.25
lastin rep, 7.10	hatchway, 5.3	sikira, 10.9
latinsko jedro, 9.3	hawse timber, 3.13	šjoleta, 2.6
let, 9.6	headsail, 9.3	škaca, 2.21
lijevi bok, 1.10	hold, 1.15	škandaj, 9.26
linica, 5.7	hull, 1.4	škaram/škeram, 9.11
ljuljna kobilica, 6.4	inner planking, 4.8	škarpel, 10.3
ljuska, 1.5	inner post, 2.16	škvara, 10.5
mali drveni čavao, 7.7	iron maul, 10.7	soha, 9.11
malj, drveni, 10.6	keel plank, 2.7	sovrnja, 6.5
malj, željezni, 10.7	keel shoe, 2.6	štil, 5.8
mrtva banda, 5.7	keel, 2.1	štiva, 1.15
mrtva statva, 2.18	keelson, 2.20	štrop, 9.14
nadgrađe broda, 5.6	knee, 3.16	stupa, 8.2
nadvođe, 1.17	knighthead, 3.13	šuraoš, 2.6
nosač vesla, 9.11	lateen sail, 9.3	svrdal, 10.11
nosivost, 1.21	lead patch, 8.6	tašel, 8.4
obnova platice, 8.4	lead sheeting, 8.5	tercarol/trcarol, 9.9
oglavno jedro, 9.3	leather strap, 9.14	timun, 9.15
olovna obloga, 8.5	limber board, 5.12	tresca, 7.11
olovna zakrpnna pločica, 8.6	limber hole, 3.9	trinkarin, 4.5
oplata palube, 5.2	lugsail, 9.3	verzina, 5.10

hrvatski/Croatian	engleski/English	narodni/vernacular
oplata, 1.13	main frame, 3.4	žbaj, 3.15
oputa, 9.4	mallet, 10.6	živa banda, 1.18
orebrenje, 1.12	mast mortise, 2.22	zoja, 3.11
osnivanje broda, 1.1	mast step, 2.21	zvir, 6.1
otvor za veslo, 9.12	mast, 9.1	
paluba, 1.14	masts, 9.4	
palubna platica/trenica, 5.1	mortise and tenon joint, 7.8	
palubna proveza, 2.25	mortise, 7.4	
palubni otvor, 5.3	moulded, 3.3	
peta krmene statve, 2.11	nail, 7.1	
peta pramčane statve, 2.9	oakum, 8.2	
pila, 10.8	oar lashing, 9.14	
platica, 4.2	oar port, 9.12	
plosna kobilica, 2.7	oar, 9.10	
podigač, 9.8	oarlock, 9.11	
podnica, 5.11	outer planking, 4.1	
podpalublje, 1.15	outrigger, 9.13	
podspojak, 2.25	overlapping floor, 3.6	
podvođe, 1.18	patched tenon, 7.6	
polurebrenica, 3.7	peg, 7.7	
poruba, 5.9	pitch, 8.3	
pramac, 1.6	plank repair, 8.4	
pramčana protupeta, 2.14	plank replacement, 8.4	
pramčana protustatva, 2.13	plank, 4.2	
pramčana statva, 2.8	planking, 1.13	
pramčano uzvojno koljeno, 2.15	plank-sheer, 4.5	
pramnica, 5.4	poop deck, 5.5	
prečka, 9.3	port(side), 1.10	
pregrada, 3.14	pulley, 9.21	
prijeklopna gradnja, 7.14	quarter rudder, 9.17	
priklad, 3.8	quick works, 1.18	
pripona, 9.5	rabbet (stem/sternpost), 2.12	
produžnik, 3.8	rabbet plane, 10.1	
protukobilica, 2.4	rabbet, 2.2	
proveza, 2.24	ram, 6.2	
pulena, 6.1	recess, 2.3	
rašlje, 3.11	rib, 3.1	
razma, 4.5	rider keel, 2.4	
rebreni nastavak, 3.8	rigging, 9.4	
rebreni utor, 2.3	rising wood, 2.5	
rebrenica nejednakih krakova, 3.6	rudder, 9.15	
rebrenica, 3.5	running rigging, 9.4	
rebro, 3.1	sail, 9.3	
ribina, 1.19	sails, 9.4	
ručica kormila, 9.18	saw, 10.8	
rudo, 9.18	saw, 10.8	
sidro, 9.27	sawing, lashing, 7.18	
stična gradnja, 7.13	scarf (joint), 7.9	
širina rebra, 3.2	scupper, 5.9	
šivanje (vezanje), 7.18	seam, 7.12	
sjekira, 10.9	sheave, 9.21	
škota, 9.7	sheer plank, 4.6	

hrvatski/Croatian	engleski/English	narodni/vernacular
slivnica, 3.9	sheer strake, 4.6	
sljubnica, 7.12	sheet, 9.7	
smola, 8.3	shelf clamp, 2.25	
snast, 9.4	shell first construction, 7.15	
sošno jedro, 9.3	shell, 1.5	
spoj na sljub (stik), 7.11	ship design, 1.1	
spoj na utor i jezičac, 7.8	ship, 1.3	
sponja, 3.15	shipbuilding, 1.2	
središnje pasmo, 2.20	shipwright's adze, 10.13	
središnji (kobilični) umetak, 2.5	shole, 2.6	
statveni utor, 2.12	shroud, 9.5	
štitna kobilica, 2.6	side, 1.8	
stolarski šestar, 10.10	sided, 3.2	
šuperenje, 8.1	sister keelson, 2.23	
šuplja glava, 9.19	skeleton first construction, 7.16	
svornjak, 7.2	skeleton, 1.11	
svrdlo, 10.11	sounding weight, 9.26	
svrdlo, lučno, 10.12	spritsail, 9.3	
temeljnica jarbola, 2.21	square sail, 9.3	
tesla, 10.13	square, 10.5	
trenica, 4.2	stanchion, 3.17	
trup, 1.4	standing rigging, 9.4	
uklada, 2.13	starboard, 1.10	
ukrepa, 1.16	stay, 9.6	
umetak (mrtvog ugla), 2.18	steering oar, 9.16	
unutarnja oplata, 4.8	stem, 2.8	
upora, 3.17	stemson, 2.15	
upravljačko veslo, 9.16	stern knee, 2.11	
utor, 7.4	stern transom, 2.19	
uzvoj, 1.20	stern, 1.7	
uzvojna kobilica, 6.4	sternpost knee, 2.17	
valosjek, 6.3	sternpost, 2.10	
vanjska oplata, 4.1	stiffener, 1.16	
veslo, 9.10	strake, 4.3	
vijenac, 3.12	stringer, 2.24	
visina rebra, 3.3	superstructure, 5.6	
vjenčanica, 3.11	tenon, 7.5	
vjenčanica, 3.12	thole, 9.11	
vjenčić, 9.14	tholepin, 9.11	
vodna linija, 1.21	thwart, 3.18	
voj, 4.3	tiller, 9.18	
vrh, 9.4	topside, 1.17	
zakrpnj jezičac, 7.6	treenail, 7.3	
završna platica, 4.6	underwater parts, 1.18	
završni voj, 4.6	wale, 4.7	
žuljnica, 4.7	water line, 1.21	
	wimble, 10.11	